

Decision Support System for Diagnosing Underwater Electrical Cables

Tymochko O.¹, Tymoshchuk O.², Timochko O.³, Boiko S.², Mazhara I.⁴, Hannoshina, I.,²
Shapran Yu.²

¹Flight Academy of the National Aviation University, Kropyvnytskyi, Ukraine

²State University of Infrastructure and Technologies, Kyiv, Ukraine

³firm AFC autofleet control, Hamburg, Germany

⁴Ivan Kozhedub Kharkiv National Air Force University, Kharkiv, Ukraine

Abstract. The object of this study is the process of generating an appropriate response by an intelligent agent when detecting and tracking an underwater electrical cable using a decision support system. The goal of the work is to develop the architecture of a decision support system for diagnosing underwater electrical cables and the main algorithms for its operation. To achieve the research goal, intelligent agents with a complex IPK architecture, which includes information, preferences (rules), and knowledge, were used. The combination of the structure of intelligent agents and the advantages of hierarchical knowledge bases allowed for the natural language representation of knowledge. The functional core of the system consists of four main agents, one of which facilitates the interaction between the user and the surrounding environment. To address the uncertainty in the cable's position on the seabed, the capabilities of fuzzy sets, describing its feature space with membership functions, were employed. The most significant results involve planning for the detection and tracking of underwater electrical cables, taking into account past decision-making experiences in similar cases and adapting them to the current situation through case-based reasoning. The importance of the obtained results lies in providing the decision-maker with a possible option for deploying an underwater vehicle based on accepted logic and rules for detecting underwater electrical cables. Further research is focused on implementing automatic target selection for intervention and developing a method for automatic modification of reasoning methods, preference rule bases, and operational knowledge.

Keywords: electrical cable, diagnostics, autonomous underwater vehicle, navigation, motion control, fuzzy sets, intelligent agent, decision support system.

DOI: <https://doi.org/10.52254/1857-0070.2024.4-64.14>

UDC: 621.331: 004.584: 629.58

Sistem de suport de decizie pentru diagnosticarea cablurilor electrice subacvatice

Tymociko O.¹, Tymoșuk O.², Timociko O.³, Boiko S.², Majara I.⁴, Hannoșina, I.,² Șapran Yu.²

¹ Academia de Zbor a Universității Naționale de Aviație, Kropyvnytskyi, Ucraina

² Universitatea de Stat de Infrastructură și Tehnologii, Kiev, Ucraina

³ Compania AFC autofleet control, Hamburg, Germania

⁴ Universitatea Națională a Forțelor Aeriene Ivan Kozhedub Harkiv, Harkiv, Ucraina

Rezumat. Obiectul acestui studiu este procesul de generare a unui răspuns adecvat de către un agent inteligent atunci când detectează și urmărește un cablu electric subacvatic utilizând un sistem de sprijinire a deciziei. Scopul lucrării este de a dezvolta arhitectura unui sistem de suport decizional pentru diagnosticarea cablurilor electrice subacvatice și principalii algoritmi pentru funcționarea acestuia. Pentru a atinge scopul cercetării, au fost utilizați agenți inteligenți cu o arhitectură IPK complexă, care include informații, preferințe (reguli) și cunoștințe. Combinația dintre structura agenților inteligenți și avantajele bazelor de cunoștințe ierarhice au permis reprezentarea în limbaj natural a cunoștințelor. Nucleul funcțional al sistemului este format din patru agenți principali, dintre care unul facilitează interacțiunea dintre utilizator și mediul înconjurător. Pentru a aborda incertitudinea în poziția cablului pe fundul mării, s-au folosit capacitățile seturilor fuzzy, care descriu spațiul său caracteristic cu funcții de membru. Cele mai semnificative rezultate presupun planificarea pentru detectarea și urmărirea cablurilor electrice subacvatice, luând în considerare experiențele anterioare de luare a deciziilor în cazuri similare și adaptarea acestora la situația actuală prin raționament bazat pe caz. Importanța rezultatelor obținute constă în a oferi decidentului o posibilă opțiune de desfășurare a unui vehicul subacvatic pe baza logicii acceptate și a regulilor de detectare a cablurilor electrice subacvatice. Cercetările ulterioare se concentrează pe implementarea selecției automate a țintei pentru intervenție și dezvoltarea unei metode pentru modificarea automată a metodelor de raționament, a bazelor de reguli de preferință și a cunoștințelor operaționale.

Cuvinte-cheie: cablu electric, diagnosticare, vehicul subacvatic autonom, navigație, control mișcare, seturi fuzzy, agent inteligent, sistem suport de decizie.

Система поддержки принятия решений для диагностирования подводных электрических кабелей
Тимочко А.И.¹, Тимошук Е.Н.², Тимочко А.А.³, Бойко С.А.², Мажара И.П.⁴, Ганношина И.Н.²,
Шапран Ю.Е.²

¹Летная академия Национального авиационного университета, Кропивницкий, Украина

²Государственный университет инфраструктуры и технологий, Киев, Украина

³компания AFC Autofleet Control, Гамбург, Германия

⁴Харьковский национальный университет Воздушных Сил имени Ивана Кожедуба, Харьков, Украина

Аннотация. Объектом исследования является процесс выработки адекватной реакции интеллектуальным агентом при обнаружении и отслеживании подводного электрического кабеля с помощью системы поддержки принятия решений. Цель работы – разработка архитектуры системы поддержки принятия решений для диагностирования подводных электрических кабелей и основных алгоритмов ее функционирования. Для достижения цели исследования использованы интеллектуальные агенты, отличающиеся сложной ИРК-архитектурой, включающей информацию, предпочтения (правила) и знания. Сочетание структуры интеллектуальных агентов и преимуществ иерархических баз знаний позволило осуществить естественно-языковое представление знаний. Функциональное ядро системы составляют четыре основных агента, один из которых организует взаимодействие между пользователем и окружающим миром. Для раскрытия неопределенности положения кабеля на дне задействованы возможности нечетких множеств, описывающих его признаковое пространство функциями принадлежности. Модифицированные операторы пространства состояний позволили описать процесс детектирования силового кабеля. Подчеркнута ключевая роль агента ActionPlanner, предназначенного для планирования управления обнаружением подводного электрического кабеля на основе интерактивной процедуры взаимодействия между лицом, принимающим решение, и системой поддержки принятия решений. Наиболее существенными результатами является планирование при обнаружении и отслеживании электрических кабелей под водой с учетом прошлого опыта принятия решений в аналогичных случаях и его адаптация к текущему состоянию путем рассуждений на основе прецедентов. Согласно данному подходу, в прошлом опыте ищут похожие случаи, определяют возможности их повторного использования, обновляют и обобщают информацию с учетом текущей обстановки. Значимость полученных результатов заключается в выдаче лицу, принимающему решение, возможного варианта использования подводного аппарата по принятым логике и правилам для обнаружения подводного электрического кабеля. Дальнейшие исследования направлены на реализацию автоматического выбора цели вмешательства и разработку способа автоматической модификации методов рассуждений, базы правил предпочтений и оперативных знаний.

Ключевые слова: электрический кабель, диагностирование, автономный подводный аппарат, навигация, нечеткие множества, интеллектуальный агент, система поддержки принятия решений.

INTRODUCTION

The renewable energy sector is rapidly shifting from land-based to offshore power plants and expanding into waters far from the shore, requiring underwater cable connections to the mainland [1]. According to industry standards and best practices for protection, all cables in waters up to 1500 meters deep must be buried 0.6 to 3 meters into the seabed [2].

The detection, tracking, and diagnostics of underwater telecommunications and power cables are carried out using visual, hydroacoustic, and magnetic methods. Modern technologies for detecting and servicing underwater infrastructure aim to minimize or even completely eliminate the use of divers due to time, technological, and accuracy limitations.

Hydroacoustic methods for detecting buried cables also face significant challenges, such as detection in shallow waters [3-4].

The most suitable method for detecting buried power cables made from ferromagnetic and

conductive materials is electromagnetic sensing.

Overcoming the limitations inherent in each detection method is achieved through the combined processing of multisensory data from sensors of different physical natures - visual, acoustic, and electromagnetic.

After studying the technical features of methods for detecting underwater electrical cables, the question arises: on which platforms and by whom will these methods be applied? The answer is clear: the detection, tracking, and diagnostics of underwater electrical cables can be performed by divers or various underwater vehicles - manned, remotely operated (ROVs), or autonomous underwater vehicles (AUVs).

The use of divers is only feasible at shallow depths and in shallow waters. However, this method is quite expensive, as it poses risks to the health and even life of the diver, is not sufficiently fast or accurate, and is characterized by subjective judgments, limited underwater time for the diver, and the need for a support vessel [5, 6].

The use of manned and autonomous underwater vehicles is an even more expensive method for detecting underwater electrical cables. However, automating the inspection processes is the primary direction for detection and diagnostics, using various sensors mounted on the platform.

The diagnostics of underwater electrical cables occur under conditions of non-stochastic uncertainty caused by difficult-to-formalize processes in the surrounding marine environment, the features of the seabed terrain and bottom sediments, navigational hazards, and other factors.

Therefore, for adequate and timely detection, diagnostics, and tracking of underwater objects based on comprehensive processing of information from machine vision systems, detection, and tracking, it is necessary to develop a corresponding decision support system (DSS) [7]. Timeliness of detection will be understood as detecting the cable within a time frame that does not exceed the specified limit. Adequacy of detection, diagnostics, and tracking of underwater objects will be defined as the degree to which the results obtained using the DSS match the data from the test case.

Traditionally, tasks in DSS are formalized using predicate calculus, various logics, fuzzy sets, or intelligent agents (IA). The latter significantly reduce the probability of operator errors when making decisions in complex environments. Accurate and timely operator responses to various situations in the process of diagnosing underwater electrical cables using an intelligent DSS (IDSS) are achieved through:

- 1) real-time processing of multisensory data from all available sources of different physical natures;
- 2) the use of a user-friendly interface;
- 3) conducting operator training under varying levels of complexity.

An intelligent agent (IA) with a multi-level hierarchical architecture, where each element is represented as a monad — a triangle of IPK (Information, Preferences, Knowledge) — was proposed in the study [8]. Information is a category that describes the state of a previously selected area of research (intervention, influence). Relative rules (preferences) rank areas of research by their importance. Knowledge transforms certain information into other information [8].

Thus, an IA, with the help of a sufficiently complex architecture and by using available information, knowledge, and preferences, can autonomously perform a specific class of tasks in a new environment [9].

Experts continue to study the properties of IAs due to the expansion of such systems into other application areas. The absence of a complete theory for formalizing abstract IAs, independent of the specific characteristics of a particular domain, necessitates the implementation of DSS prototypes to identify significant limitations. The integration of various DSS systems will allow the creation of an architecture that is entirely independent of the subject area [9].

Thus, modern advances in visual and hydroacoustic tracking of large underwater objects [3] and electromagnetic detection of underwater infrastructure [10] highlight the need to develop the architecture of an intelligent decision support system (IDSS) for detecting, diagnosing, and tracking underwater electrical cables, as well as the main algorithms for its operation.

The main characteristic features of an electrical cable for its recognition on a flat image and subsequent classification in the DSS are presented in [11]. A significant decrease in the quality of underwater visualization of power lines is noted due to insufficient natural and artificial external lighting (Figure 1).



Fig. 1. Photographs of underwater electrical cables.

The issues of improving the temporal and accuracy characteristics of localizing underwater cables in underwater images using Laplacian-Gaussian filtering are addressed in [12], edge detection in [13], and Kalman filtering in [14].

A six-stage process for visual tracking of underwater cables is discussed in [14]. The original 24-bit red, green, blue (RGB) image was converted to an 8-bit grayscale image. The Perona-Malik filter, which uses the Sobel edge detector and Hough transform, preserved the image contrast for detecting extended boundaries of communications. Various a priori shapes, such as polynomials or non-homogeneous second-order B-spline curves, were used to describe the boundaries during the regularization process.

In the process of recognizing the electrical cable, the AUV navigates and moves underwater in a straight line along objects of a rectangular elongated shape of uniform color [15].

The development of a machine vision system and its integration with tracking systems is the foundation for creating a DSS for detecting and diagnosing underwater power lines [7].

Tracking is a more complex task than detecting underwater electrical cables during diagnostics [16]. Improving the navigation of the AUV along the detected section of the electrical line is achieved by integrating information from visual and electromagnetic sensors.

To overcome the determinism and ambiguity of methods for boundary determination, line extraction, segmentation, or texture description in the marine environment, a stochastic method has been proposed. It is based on particle filters that incorporate motion and observation models [17].

The hypothetical configuration of cable variables (possible shapes, alignments, colors, and probabilities of occurrence), represented as a state in the corresponding state space and the weight of its importance, is called a particle.

The motion model evaluates the probability of the posterior position and orientation of the electrical cable underwater based on the prior probability density function of the cable parameters. The observation model weights the particles according to the available data by matching each particle with an existing template. The final decision regarding the location of the desired object is made based on the resulting probability density (Figure 2).



Fig. 2. (left) Typical underwater cable; (right) assumed position of the cable.

Excluding elements with low weights reduces the errors of degeneration when estimating the position of the cable [4]. The authors also proposed an algorithm for recognizing the cable based on its axis rather than both of its boundaries. For this purpose, horizontal and vertical mask filters are used in the observation model instead of a filter oriented perpendicular to the cable.

This approach allowed the AUV to be raised above the surface of the seabed. The evaluation of the particle was performed based on the average response values, and the convolution of the current

image significantly accelerated the process and improved recognition quality in the optical range (Figure 3).



Fig. 3 (left) Original image of the cable; (right) evaluation of the cable (light line) after processing the original image.

However, the method of visual inspection carries a fairly high risk of error, is only effective at a limited distance from the object of interest and does not allow for the diagnosis of buried power cables and power lines.

Although magnetometers and sonars are bulkier, energy-intensive, expensive, and sensitive to background noise [14] compared to visual inspection [18], they are still more effective in complex conditions.

The method of echolocation for underwater electrical cables is based on identifying segments with noticeable straight lines that differ in thickness, color intensity, geometry, appearance close to the background, etc. [19]. The authors demonstrated the vulnerabilities of the Hough transform, which can lead to Type I and Type II errors when making decisions about the presence of a cable on the seabed while detecting isolated, unrelated elements.

A universal method of acoustic probing has been proposed. The sequential execution of noise suppression, amplification, and threshold processing by the sonar allows for the detection and classification of underwater electrical cables upon receiving a response to the transmitted acoustic signal. Considering the characteristics of wave propagation in other frequency ranges in water and sediment will require some technical refinements of specific stages and significantly expand the capabilities of detecting underwater electrical cables.

In work [19], high-resolution side-scan sonars (SSS) with a resolution of up to $0.5^\circ \times 0.03$ m and a long operational range (up to 2×120 m) were investigated for recognizing and tracking underwater cables as thin and elongated objects. The presence of the electrical cable in a high-sensitivity zone from the SSS platform allowed for real-time tracking of the cable. An adequate motion model for the AUV with the SSS was used at a height of approximately 5–15 m above the

seabed. The lateral deviation of the search object was about 5–40 m from the platform.

In works [20, 21], a sonar for scanning submerged objects (SSSO) that are masked by noise is investigated. The noise is generated by inhomogeneities in the sedimentary rocks, roughness of the water-sediment interface, and greater attenuation of compressional waves in the sediments compared to water. The SSSO operates at lower frequencies compared to the SSS.

Submerged objects do not have an acoustic shadow. This is explained by the high diffraction around the underwater cable, the passage of the signal through it, and the high level of acoustic noise caused by backscattering from the sedimentary rocks. Therefore, the SSSO is equipped with a multi-channel planar hydrophone array with an operational frequency range of 5–23 kHz [20] or 2–12 kHz [21], capable of detecting cylindrical objects submerged up to 30 cm when the scanning beam strikes at an angle of no more than 45°.

Unlike traditional sonar, the SSSO synthesizes not three-dimensional images but point images when detecting a cable, utilizing the boundary gradient and measuring the signal reflected only from the orthogonal part of the object's surface.

The study of a broadband sonar operating in the frequency range of 30–130 kHz, capable of detecting cables with a diameter of less than 25 mm on various types of sediment at different angles of sonar pulse sliding across the seabed, is presented in work [22]. The sonar can differentiate between types of cable materials based on scattering theory for thin cylindrical shells. The exact position of the cable is determined using sets of Haralick features, which analyze changes in the values of normalized quantized spectra in the responses of search objects.

The research on the rapid attenuation of acoustic or optical waves underwater, which limits the range of sensors compared to their terrestrial, aerial, or space counterparts, is described in [23].

The conditions of the seabed, disturbances at the "air-sea" and "sea-bottom" interfaces, complex topographic profiles of the bottom and submerged objects, and the high density of artificial obstacles complicate acoustic research in the coastal zone, especially in shallow waters, often leading to false alarms when only acoustic sensors are used [24].

Work [25] discusses a frame with two perpendicular planes and three separate search coils for cable detection. Two coils, with their main axis in a horizontal direction and placed one

above the other at a distance of 0.5 m, detect a field perpendicular to the cable. The main axis of the third coil, positioned vertically, allows for determining the direction of the cable (Figure 4).

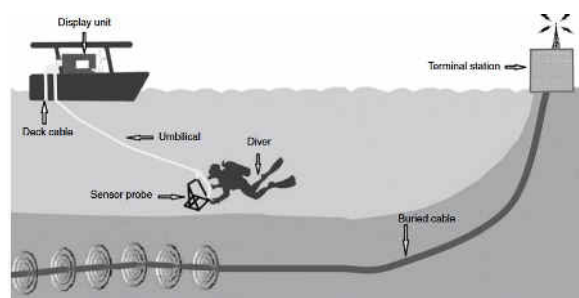

Fig. 4. Diagram of monitoring an underwater cable carried out by a diver (based on materials from [25]).

The determination of the exact location of the cable in horizontal and vertical directions using a sensitive magnetic sensor, based on the minimum total quadratic error of the measured data extracted through Fourier analysis from a 50 Hz signal and its harmonics, is described in work [26]. However, the device picks up more noise than target objects in areas with a high concentration of electrical cables and with very precise instrument settings. If the voltage difference across the two coils is less than the noise level, it becomes impossible to assess the cable's location due to significant error.

Additionally, it is necessary to consider an influence of the signal propagation medium underwater [27].

Work [28] presents analytical equations for the propagation of low-frequency magnetic fields in conductive (metal or seawater) and non-conductive media (soil).

The magnetic field of alternating current (AC) in submerged cables can only be measured in close proximity to the cable using detection coils [29–31]. The autonomous underwater vehicle determined the value of the magnetic field after visually inspecting and recording the cables. After detecting the cable, the platform tracked it using proportional-integral-derivative (PID) and fuzzy controllers, turning towards the cable while maintaining a height of 1–2 m. The horizontal and vertical distances from the cable were calculated based on the angle between the platform's direction of movement and the cable, as well as the distance between two sensors, considering the roll and pitch angles of the underwater vehicle [30].

Noise from direct current (DC) electric motors, battery currents, and motors driving thrusters and rudders negatively impacts the accuracy of the platform. For instance, reducing the noise level

from the platform to 0.05 nT improves the detection range of the cable to 60 m [31].

Methods for detecting underwater power cables by the magnetic field induced by direct current (DC) using AUVs, in which search coils are replaced by ferromagnetic magnetometers, are proposed in the study [32].

The detection of underwater mines and unexploded ordnance (UXO), as well as power and telecommunications cables using electromagnetic pulse induction methods, is asserted to have the same physical nature in work [33].

Processing aggregated data from multiple sensors of different physical natures increases the likelihood of detecting and correctly classifying ferromagnetic UXOs, especially those that are submerged, as stated in article [34]. By integrating a real-time gradiometer and SSSO, and compensating for noise caused by the rotation of the AUV, variations in the seabed, and surface roughness, the authors localized ferromagnetic objects at short distances on various types of seabed.

Features from both sensors, transformed from the original distributions into Gaussian distributions, were sent to a joint Gaussian-Bayesian classifier after calculating covariance to determine the object using the log-likelihood test (Figure 5).

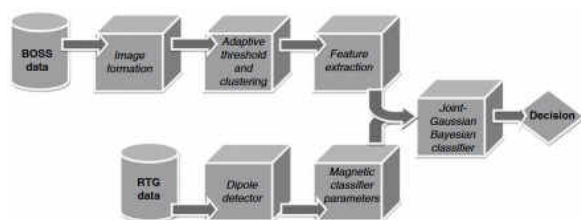

Fig. 5. Acoustic and magnetic sensor fusion system (redrawn from [34]).

Article [35] describes a general model of abstract IA. Three simple agents — Direct-Advisor, InfoProvider, and IDAPlanner — form the functional core of the intelligent advisor of the DSS, which organizes interaction with the user and the external environment. The intelligent advisor plans solutions that are adequate to the evolving situation. Within the framework of the model, an IPK architecture of the intelligent agent is proposed, designed for specific tasks.

The determination of the cable's position based on the integration of cable localization algorithms and magnetic guidance and control of the inspection AUV is described in reference [36].

The paper [37] presents a method for

developing a virtual environment for monitoring underwater electrical cables using AUVs based on fuzzy cellular automata. However, the method is not adapted to solve multi-parameter optimization tasks.

Changes in the behavior of the intelligent agent depending on the evolving situation based on cellular automata are investigated in reference [38].

Reference [39] discusses a decision support system (DDS) for planning and managing the AUV mission in a complex ocean environment in near-real-time. This is achieved through the application of multi-criteria decision analysis, analytic network processes, and fuzzy sets. However, the mission planning system has not yet been supplemented with an intelligent hierarchical layer for detecting electrical cables.

The paper [40] discusses an approach to solving the problem of simultaneous localization of search objects and map building. However, the accuracy of the method implemented in the DSS is insufficient.

The paper [41] examines a hierarchical approach to global route planning for AUVs based on a genetic algorithm. However, the DSS cannot ensure the detection of cables in conditions of partial or complete burial or concealment in certain areas.

Research on the architecture of the IDSS for studying the behavior models of unmanned systems in search operations is still ongoing. A pressing issue is the development of DSS architecture for diagnosing underwater electrical cables and the core algorithms for its operation.

Thus, the use of a modified IPK architecture in the DSS allows for the development of precise, easily implementable, and adaptable algorithms for detecting and diagnosing underwater electrical cables using AUVs.

The goal of the research is to develop DSS architecture for diagnosing underwater electrical cables and the core algorithms for its operation.

METHODS, RESULTS, AND DISCUSSION

An intelligent agent, possessing a high degree of autonomy, a wide range of solvable tasks, means to achieve goals, and possible levers of influence on the situation, can independently reach the primary objectives of the system's functioning by accumulating knowledge, learning, and planning its actions.

If the knowledge K and preferences P cannot fulfill the agent's task, they generate data for a higher-level triangle and become a new domain themselves. That is, the knowledge base (KB) of

each monad is an external element at a lower meta-level. This is a necessary prerequisite for the creation of hierarchical databases (DB), in which logical reasoning is also hierarchical.

Thus, the structure of the intelligent agent (IA) with a hierarchical knowledge base (KB) proved to be extremely convenient for the natural language representation of knowledge in the developed intelligent decision support system (IDSS). The intelligent agent aggregates information about the real underwater environment, rules, and knowledge, forming the foundational ontological platform for the DSS (Figure 6). In the figure, the following are

indicated: D – goal; I – information; K – knowledge; P – preferences (rules); M – monad; KB – knowledge base.

Full-fledged functioning of the DSS requires the description not only of possible methods of influence but also the formalization of environmental domains. By highlighting a generalized representation of objects of interest and the surrounding environment, along with existing and necessary resources, the process of detecting and tracking underwater electrical cables can be considered in a dynamic context.

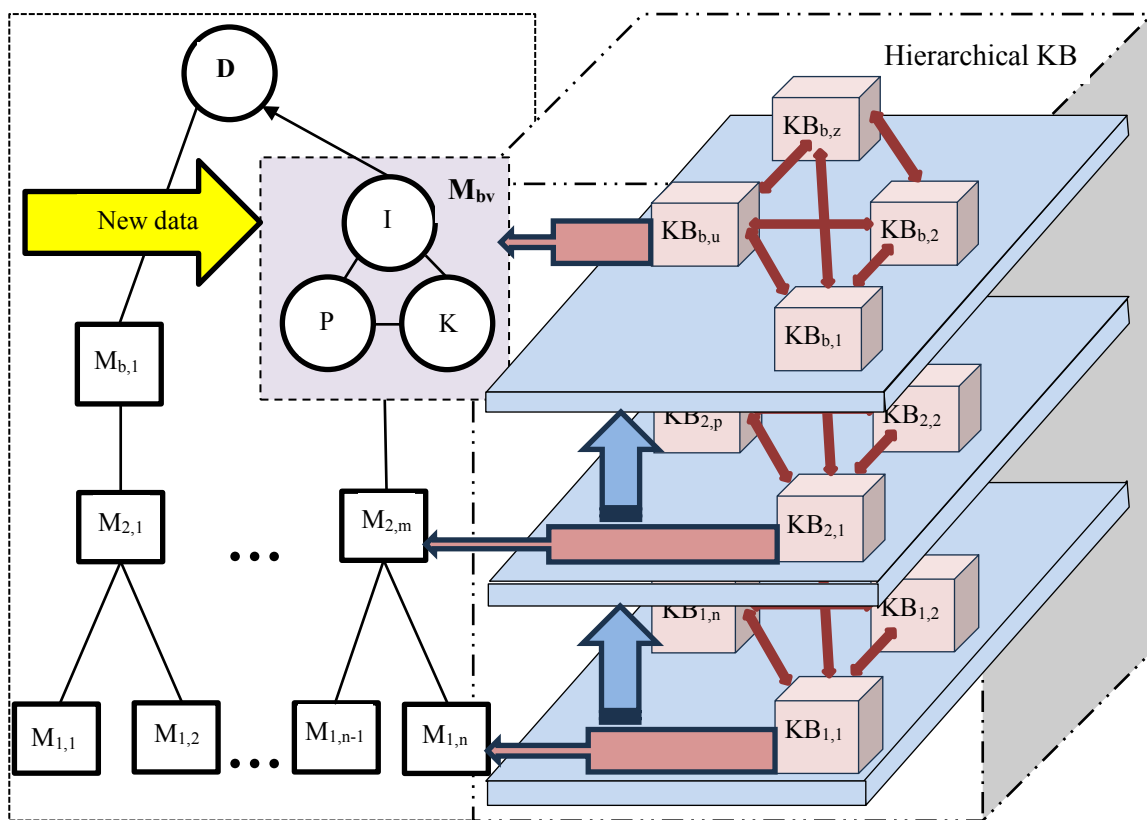

Fig. 6. Integration of the IPK architecture of the intelligent agent with the knowledge base.

To achieve this, it is necessary to perform a functional decomposition of the intelligent agent into object prototypes – MainAdvisor, InfoProvider, ActionPlanner, and PrecedencyManager (Fig. 7).

The MainAdvisor organizes the interaction between the user and the external environment based on information from the InfoProvider. The ActionPlanner, as the intelligent advisor for action

planning, formulates appropriate actions for the effective execution of the mission of the AUV in the dynamics of the evolving situation.

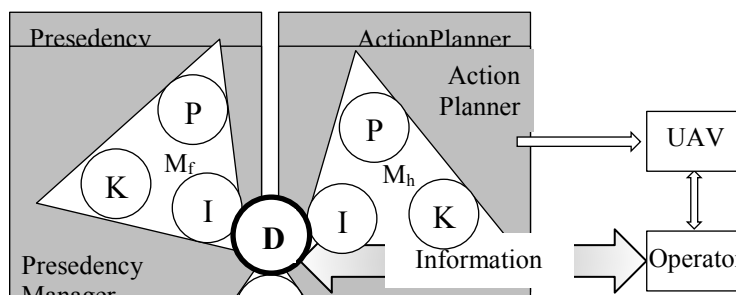

Fig. 7 – Decomposition of the IPK structure of the intelligent agent into components.

The decision support system (DSS) provides the decision-maker (DM) or the execution mechanisms of the AUV with a feasible option for detecting or tracking the cable, considering the accepted logic, rules, and available resources.

To plan the operation of the decision support system (DSS) for detecting or tracking an underwater electrical cable, we present a model for searching the object over time within the declarative (descriptive) knowledge domain KD_j :

$$KD_j : I_i \rightarrow I_{i+1}, \text{ for } i=1, 2, \dots,$$

where I_i, I_{i+1} represent the information describing the state of the sought object (the area of activity of the monad) at different moments in time.

Each specific element of the subject domain can be represented as an instance of an object or resource, with object classes being cable types.

In the DSS, the states of search objects are represented by fuzzy sets with membership functions (MFs) corresponding to specific variables (depth of burial, embedding, location accuracy, detection efficiency, object shape, color uniformity, operational depth of acoustic location, detection range of SSS, sonar beam incidence angle) (Fig. 8 a-j).

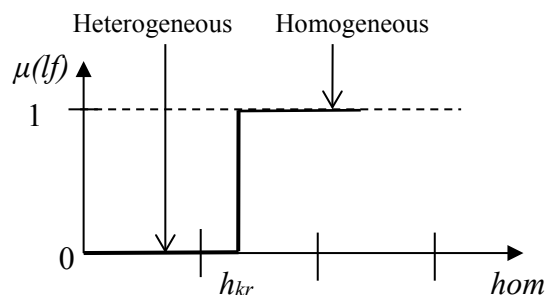
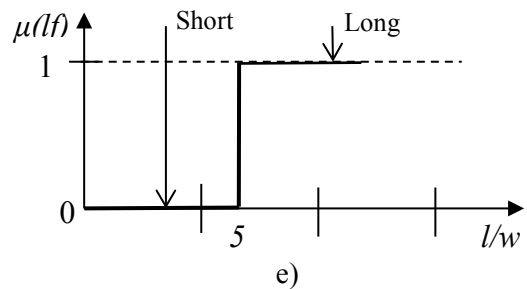
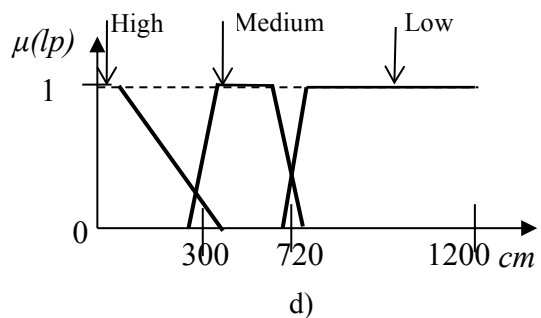
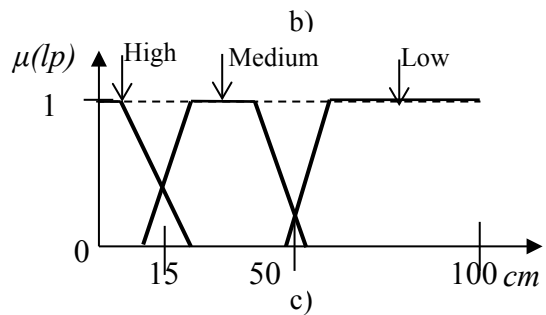
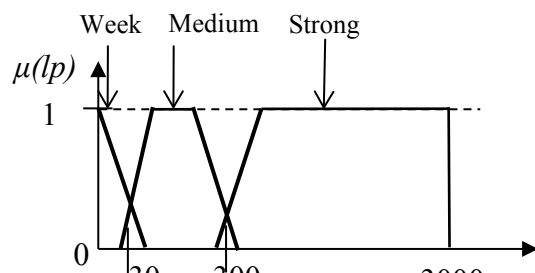
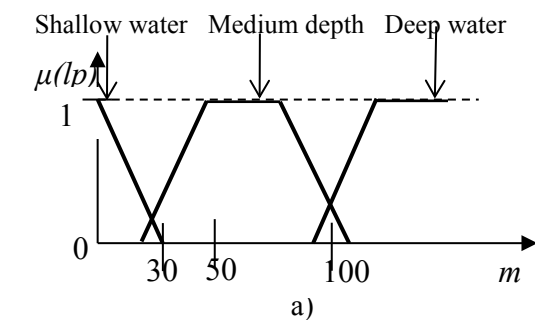

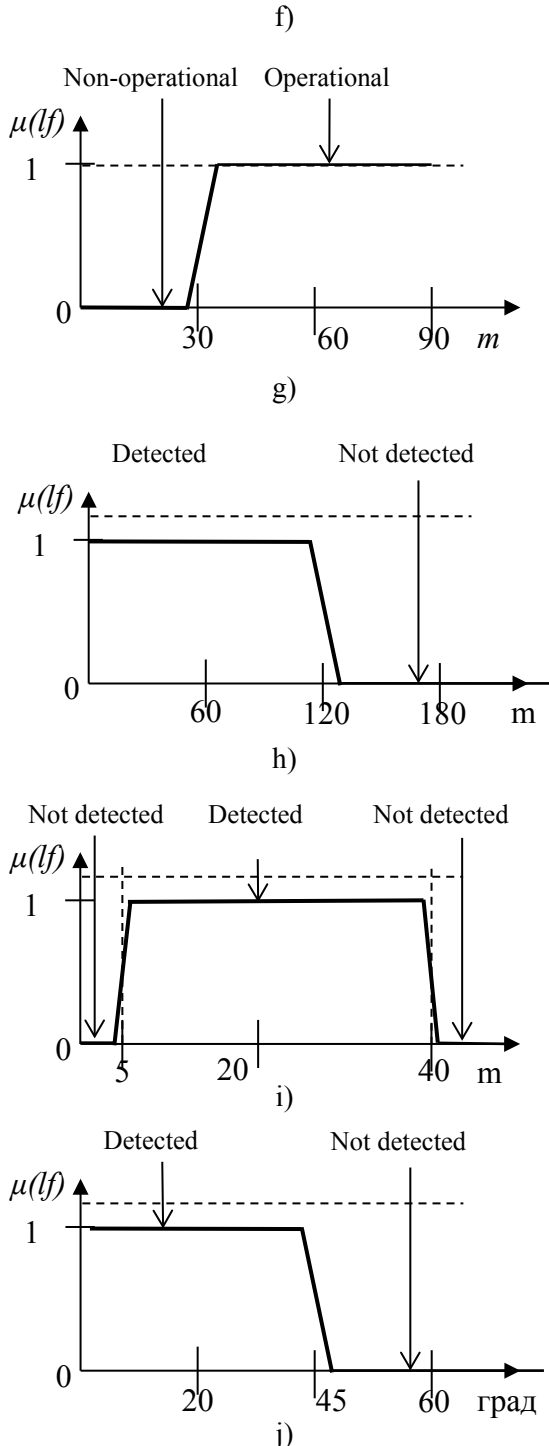

Fig. 8. Fuzzy membership functions of object parameters in describing the situation "Search for an underwater electric cable".

When detecting an electric cable, the executive manager performs a specific action j , using operational knowledge KO_j and showing how

the description of the domain changes from I_i to I_k after the action is performed: $KD_j : I_i \rightarrow I_k$.

In this DSS, actions are represented as fuzzy sets with MF $\mu(\varepsilon)$, and the state space operator is a triplet $(\varphi, \mu(\varepsilon), \omega)$. In this triplet φ is the premise of fuzzy actions that need to be executed to apply the operator α for transitioning the environment to state ω (post-condition) with a membership function $\mu(\varepsilon)$.

The modified state space operators allow for describing the complex action of searching for a power cable underwater:

- 1 Preconditions: $\{obj(T, t) \wedge form(T, extended) \wedge color(T, homogeneous) \wedge burial\ area(T, shallow\ water)\}$
 Postconditions: Delete List: $color(T, homogeneous) \wedge burial\ area(T, shallow\ water)$
 Add List: $color(T, heterogeneous) \wedge burial\ area(T, deepwater);$
- 2 Preconditions: $\{obj(T, t) \wedge burial(T, medium) \wedge sonarCableDetectionRange(T, undetected)\}$
 Postconditions: Delete List: $burial(T, medium) \wedge sonarCableDetectionRange(T, undetected)$
 Add List: $burial(T, small) \wedge sonarCableDetectionRange(T, detected).$

For detecting (tracking) underwater electrical cables, the DSS performs systematic actions that must align with the competencies of a qualified operator. The successful execution of such actions requires specific resources.

Thus, the functional agents — MainAdvisor, InfoProvider, ActionPlanner, and PrecedencyManager — form the architecture of the IDSS, which is implemented using the visual modeling tool Rational Rose with UML notation.

Using the MainAdvisor, InfoProvider, and ActionPlanner agents, the following tasks are autonomously performed:

- 1) representation of the current state of the underwater search object;
- 2) continuous updating of data about the search object and the user's goals as new information is received from the InfoProvider agent;
- 3) providing the decision-maker with an action plan from MainAdvisor;

- 4) predicting the search outcome at the request of MainAdvisor or after performing a specific action.

The PrecedencyManager agent essentially serves as the rule base for detecting and tracking the underwater cable. It coordinates the interaction of all components of the DSS in the process of cable detection (tracking) according to the initial state of the external environment, implementing the practical steps to achieve the DSS's operational goals.

The InfoProvider agent, acting as the common interface between the IDSS user and other agents, transmits up-to-date information about the actual state of the search area and available resources. All information about the search object is mapped to the abstract application domain of the DSS. Additionally, this agent manages the database on demand and presents information at a higher level of abstraction.

Relational databases store information, goals, and operational knowledge of the user:

Objects – a list of objects in the subject area, divided into fixed classes;

ObjectState – the values of the attributes (states) of an object at any given time;

Resources – lists of resource objects;

Resource State – the value of the attributes (states) of a resource at any given time;

List of Goals – a list of local intervention (impact) goals;

Set of Actions – a set of actions corresponding to the selected roles of the search manager.

The database is connected to other modules and provides a unified mechanism for the functioning of the DSS.

The database contains abstract conceptual information about the electrical cable: possible facts, actions, and goals, knowledge about the order of searching for the cable, and standards for resource usage for each class of search object, as well as data on similar events (historical data).

The database stores current (actual) information about the electrical cable, instances of objects, and resources involved in the process of detecting and monitoring the cable and navigating the AUV.

The ActionPlanner agent is designed to solve the problem of planning the management of detecting the underwater electrical cable, applying an interactive procedure for interaction between the decision-maker (DM) and DSS (Figure 9):

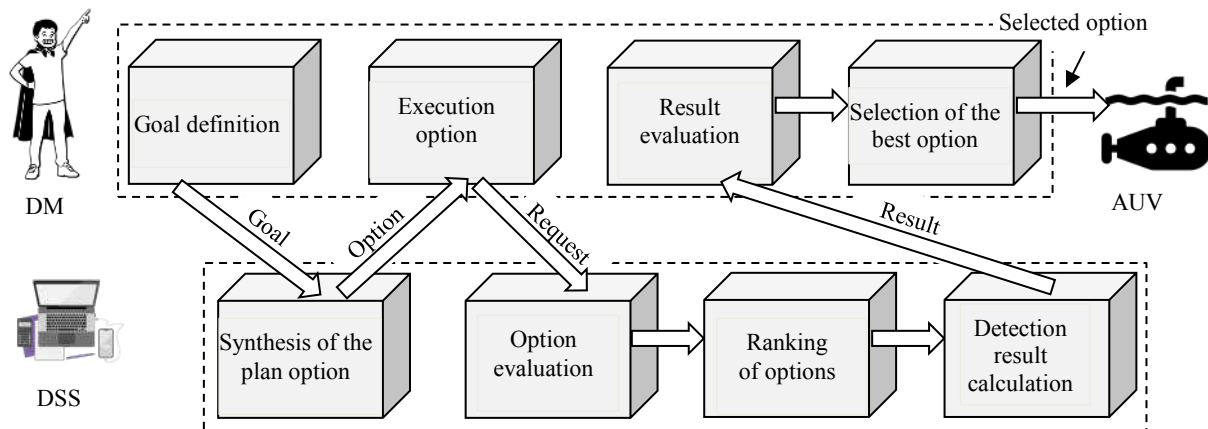

Fig. 9. Organization of interaction between the decision-maker and the decision support system in the search (monitoring) of the underwater electrical cable.

- 1) The decision-maker identifies specific goals for searching (monitoring) the underwater power cable to maintain control over the critical search area.
- 2) The DSS suggests appropriate management actions to the decision-maker, considering goals, losses, and gains.
- 3) The system responds to the DM's requests after each management action and provides forecasts.

- 4) Possible consequences indicate what actions the decision-maker needs to take.

After selecting the necessary sensors, navigation modes, and movements of the AUV, the decision support system provides the operator with the results of recognizing the underwater electrical cables.

To perform these functions, the ActionPlanner agent consists of the following components: a controller, a simulator (including an environment simulator), and a case-based reasoning (CBR) module.

The competencies of the ActionPlanner agent are:

- 1) organizing information exchange during the decision-making process;
- 2) presenting the current state of the environment and continuously updating information;
- 3) clarifying the user's goals informed by the InfoProvider agent;
- 4) planning actions or sequences of actions for the MainAdvisor;
- 5) predicting the state of the environment for the MainAdvisor and the outcome of the mission resulting from any given action.

The ActionPlanner class (C++ class) is implemented as a comprehensive planning module based on network planning and management methods (Network Planning and Management, *NPM Planner*).

The NPMPlanner class allows for system expansion, is universal, and is represented as the NPMPlanner agent, which is the current implementation of the ActionPlanner.

In general (without the DSS), the AUV or diver operates in a complex dynamic environment while searching for an underwater electric cable, encountering many different objects and unexpected task execution conditions. Achieving the operational goals of the AUV during detection is accomplished through the synchronous functioning of all its systems, primarily sensors of various physical natures and navigation equipment. Many factors influence these systems, including hydrometeorological conditions, physical constraints, human factors, and more. While the movement of the AUV or the influence of environmental factors on the cable can be estimated with a certain probability, the behavior of the operator (or diver) is not always predictable.

Thus, when planning the detection of underwater electric cables, the consequences of any specific action are not known a priori and can only be predictive when a process-oriented approach is used, where goals are localized at a higher level of abstraction (meta-level). Therefore, the highest goal, derived from the agent's maximum preferences, may be to constantly keep the section of the cable of maximum length under control.

The effectiveness of planning for the detection and tracking of underwater electric cables is based on past decision-making experiences in similar cases and their adaptation to the current state through reasoning based on precedents (CBR) [42]. According to the CBR approach, the most

similar cases are sought in the past, opportunities for their reuse are identified, and information is updated and generalized based on the acquired experience (Fig. 10).

NPMPlanner organizes meta-rules at the first meta-level based on optimizing the value function and utilizes CBR methods to accelerate planning.

In the process of detecting (tracking) the cable in new conditions, efforts are always made to find similar (or very closely related) cases (precedents) from the past and to apply already known solutions again. The data is then reviewed and updated based on the newly acquired experience. If none of the discovered precedents directly suit reapplication, generalization or specialization procedures are undertaken. The essence of generalization lies in finding commonalities among several cases. The primary focus of specialization is to achieve the required degree of similarity between the new case and the precedent by removing secondary details from the new case. This process functions similarly to machine learning procedures in artificial neural networks, where the outcome is calculated based on similar situations from the past and the reuse of knowledge in analogous cases.

The CBR approach involves the use of a precedent (case). In general, a precedent is a structured representation of accumulated experience in the form of data and knowledge about a problematic situation and its automated solution through the execution of specific actions using specialized software systems. The accumulated base of precedents is highly specific to a particular subject area.

To implement the procedure based on precedents for detecting underwater power cables, the individual components of *NPMPlanner* (Figure 11) perform the following functions:

- the controller organizes the study of new experiences from real and simulated environments;
- the simulator executes a sequence of simulation steps according to the specified strategy;
- the simulation environment mimics conditions close to reality to study the transition between states during the execution of a given action;
 - the CBR component manages the action precedent base and the Q-function precedent base (state-action functions).

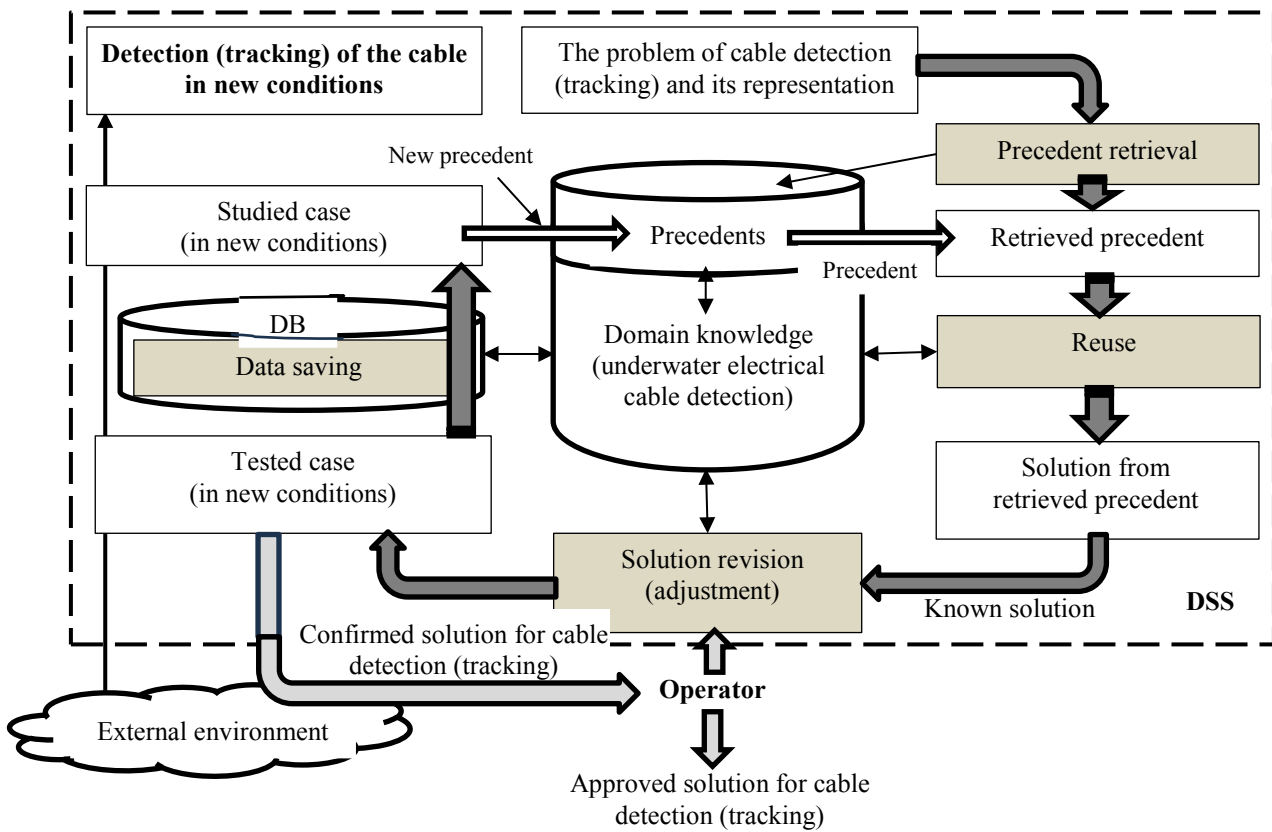

Fig. 10. Cycle of CBR Method Functioning.

The use of the NPM framework has allowed for the modeling of complex actions with varying durations and the execution of certain actions in parallel.

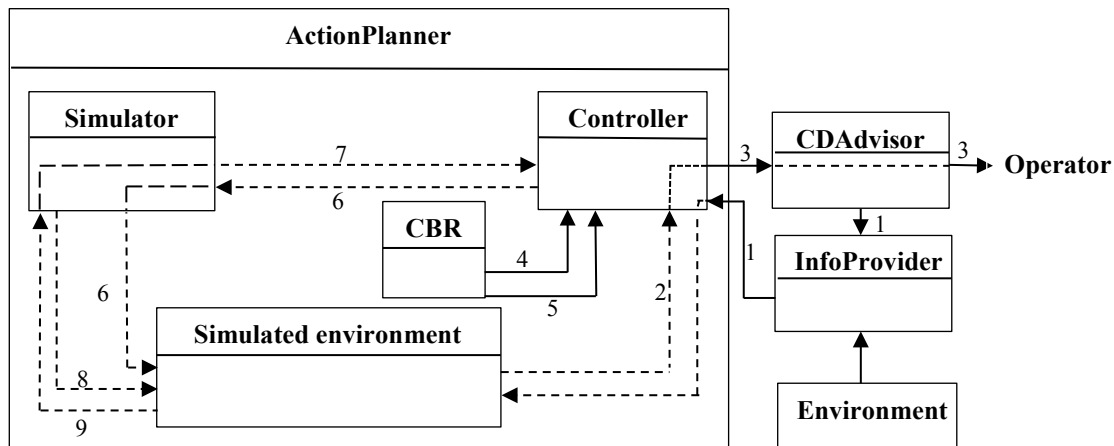

Fig. 11. Architecture of the Decision Support System (DSS) with specialization of the ActionPlanner agent (CDAdvisor = MainAdvisor Agent), UML notation

- 1 – sent action, new target state; 2 – optimal action, achieved action; 3 – proposed action; 4 – received action;
- 5 – obtained Q-function ("state – action"); 6 – initial state; 7 – simulating action, subsequent state;
- 8 – updated Q-function; 9 – applied action; 10 – actual state.

Subordinate agents (see Fig. 11) perform all control actions when detecting underwater electric cables, exchanging messages among themselves as well as with executors (including operators and

actuators of the AUV) and experts.

CDAdvisor organizes information exchange between sources and the impact planner and directly with the operator, effectively serving as

the interface.

The user (operator) interacts with the Decision Support System (DSS) through CDAdvisor when setting up the domain map; configuring initial data, type and characteristics of the target object, possible impact goals, and the role of the AUV (operator); and demonstrating detection management. The latter case illustrates the scenario of detecting an underwater electric cable under relatively simple conditions, where the operator can change (update) certain environmental conditions, possible operations (manipulation, connecting sensors, influencing actuators, etc.), and the corresponding detection (tracking) rules using the interface of the CDAdvisor component.

When detecting an underwater cable under typical (normal) conditions, the DSS suggests a standard (typical) sequence for using sensors to the operator. Using a forward expansion approach, the operator assesses the possible consequences of this sequence and develops an action plan to define the operation's objective, utilizing the preference database.

If the DSS does not assist the operator, they independently select the necessary information sources and actions and carry them out. The presence of the DSS restricts the operator's choice of actions to those proposed by the system.

The overall algorithm of the DSS functioning is illustrated in Figure 12.

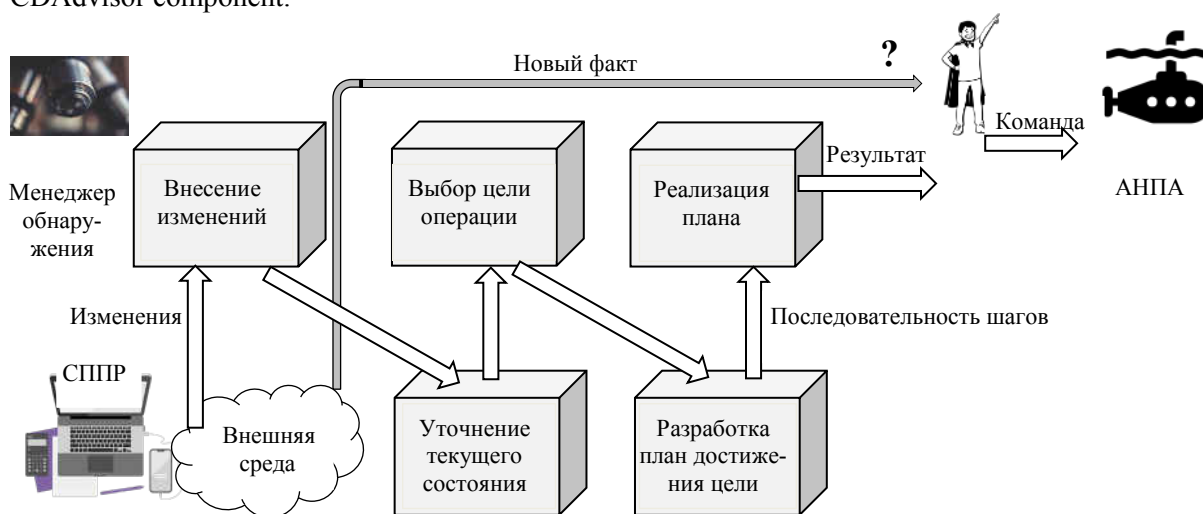

Fig. 12. Overall Algorithm of the Decision Support System Functioning.

The user interface of the Decision Support System (DSS) consists of a main window that serves as a starting point and a series of panels designed for input/output of necessary information, goals, and knowledge.

CONCLUSIONS

The proposed Decision Support System (DSS) takes into account the characteristics of a specific abstract intelligent agent, focusing on representing descriptive knowledge of the subject area in the form of fuzzy sets and modeling it in object-oriented languages.

The conceptualization of knowledge about the detection and tracking of underwater electrical cables as STRIPS-like operators, extended with fuzzy sets and corresponding membership functions, has allowed for the creation of a qualitatively new apparatus for formalizing the DSS.

Future research will aim to implement a

preference management agent with automatic selection of intervention goals. To facilitate the automatic modification of reasoning methods, preference rule bases, and operational knowledge, work is underway to separate all circulating information within the system according to structural meta-levels of the DSS.

The solution to the task of developing a model of descriptive knowledge, tested in other specific domains of the Intelligent Decision Support System (IDSS) under conditions of uncertainty and incomplete information, will enable the creation of an unchanging, repeatable, incremental, and recursive architecture for the IPK core of the decision support system.

References

[1] Jay S. (2011). Mobilising for marine wind energy in the United Kingdom. *Energy Policy* 39: 4125–4133.
 [2] Carter L, Burnett D, Drew S, Marle G, Hagadorn L, BartlettMcNeil D and Irvine N.

- (2009). Submarine cables and the oceans – connecting the world. UNEP-WCMC Biodiversity Series No. 31. ICPC/UNEP/UNEP-WCMC.
- [3] Szyrowski T, Sharma SK, Sutton R and Kennedy GA. (2013a). Developments in subsea power and telecommunication cables detection: Part 1 – Visual and hydroacoustic tracking. *Underwater Technology* 31: 123–132.
- [4] Ortiz A, Antich J and Oliver G. (2009). A Bayesian approach for tracking undersea narrow telecommunication cables. *OCEANS 2009 - EUROPE*, 11–14 May, Bremen, 1–10.
- [5] Simo M, Ortiz A and Oliver G. (2000). Optimized image sequence analysis for real-time underwater cable tracking. *OCEANS 2000 MTS/IEEE Conference and Exhibition* 1: 497–504.
- [6] McFarlane JR. (2008). Tethered and untethered vehicles: The future is in the past. *OCEANS 2008*, Quebec City, QC, 1–4.
- [7] Narimani M, Nazem S and Loueipour M. (2009). Robotics vision-based system for an underwater pipeline and cable tracker. *OCEANS 2009 – EUROPE*, 11–14 May, Bremen, 1–6.
- [8] Gadowski, A.M. (1994). TOGA: a methodological and conceptual pattern for modelling of abstract intelligent agent. *Abstract Intelligent Agent, 1993*, A. M. Gadowski (Ed.) Published by ENEA, Rome, February, pp. 5–25.
- [9] Gadowski, A.M. and Di Costanzo, G. (1996). Intelligent decision support system for industrial accident management. In *Proceedings of 8th European Simulation Symposium*, A.G. Bruzzone and J.H. Kerckhoffs (Eds.), SCS International Press, Genoa, pp. 137–141.
- [10] Szyrowski T, Sharma SK, Sutton R and Kennedy GA. (2013). Developments in subsea power and telecommunication cables detection: Part 2 – Electromagnetic detection. *Underwater Technology* 2013;31:133–143. doi: 10.3723/ut.31.133.
- [11] Hallset JO. (1991). A prototype autonomous underwater vehicle for pipeline inspection. *Advanced Robotics, 1991. Robots in Unstructured Environments, 91 ICAR., Fifth International Conference* 2: 1565–1568.
- [12] Balasuriya A and Ura T. (2002). Vision-based underwater cable detection and following using AUVs. *OCEANS '02 MTS/IEEE* 3:1582–1587.
- [13] Ortiz A, Simo M and Oliver G. (2000). Image sequence analysis for real-time underwater cable tracking. *Applications of Computer Vision, 2000, Fifth IEEE Workshop*. 4–6 Dec, Palm Springs, CA, 230–236.
- [14] Asif M and Arshad MR. (2006). An active contour and Kalman filter for underwater target tracking and navigation. In: *Lazinica A (ed.). Mobile Robots Towards New Applications*. Germany: I-Tech Education and Publishing, 373–392.
- [15] Ito Y, Kato N, Kojima J, Takagi S, Asakawa K and Shirasaki Y. (1994). Cable tracking for autonomous underwater vehicle. *Proceedings of IEEE Symposium on Autonomous Underwater Vehicle Technology (AUV'94)*, 19–20 July, Cambridge, MA, 218–224.
- [16] Inzartsev AV and Pavin AM. (2008). AUV cable tracking system based on electromagnetic and video data. *OCEANS 2008 – MTS/IEEE Kobe Techno-Ocean*, 1–6. doi:10.1109/OCEANSKOB.2008.4531082.
- [17] Wirth S, Ortiz A, Paulus D and Oliver G. (2008). Using particle filters for autonomous underwater cable tracking. *IFAC Workshop on Navigation, Guidance and Control of Underwater Vehicles*. Killaloe, Ireland, 161–166.
- [18] Antich J and Ortiz A. (2003). Underwater cable tracking by visual feedback. *Pattern Recognition and Image Analysis: Lecture Notes in Computer Science* 2652: 53–61.
- [19] Isaacs JC and Goroshin R. (2010). Automated cable tracking in sonar imagery. *OCEANS 2010*, 20–23 Sept, Seattle, WA, 1–7.
- [20] Schock SG, Tallier A, Wulf J, Sara J and Ericksen M. (2001). Buried object scanning sonar. *IEEE Journal of Oceanic Engineering* 26: 677–689.
- [21] Schock S and Wulf J. (2003). Buried object scanning sonar for AUVs. *OCEANS 2003. Celebrating the Past . . . Teaming Toward the Future (IEEE Cat. No.03CH37492)* 1: 494–499.
- [22] Capus C, Pailhas Y, Brown K. and Lane D. (2010). Detection of buried and partially buried objects using a bio-inspired wideband sonar. *OCEANS 2010 IEEE*, 24–27 May, Sydney, 1–6.
- [23] Whitcomb LL. (2000). Underwater robotics: out of the research laboratory and into the field. *Robotics and Automation, 2000. Proceedings. ICRA '00. IEEE International Conference* 1: 709–716.
- [24] Pei YH, Yeo HG, Kang XY, Pau SL and Tan

- J. (2010). Magnetic gradiometer on an AUV for buried object detection. *OCEANS 2010*, 20–23 Sept, Seattle, WA, 1–8.
- [25] Tinsley. (2012). Available at <http://www.tinsley.co.uk/products/submarine-cable-test-equipment/5930.htm>, last accessed <23 September 2024>.
- [26] Wang P, Goddard K, Lewin P and Swingler S. (2011). Electromagnetic field application to Underground Power Cable Detection. In: 17th International Symposium on high voltage engineering. 22–26 August 2011, Hannover, Germany.
- [27] Al-Shamma'a AI, Shaw A and Saman S. (2004). Propagation of electromagnetic waves at MHz frequencies through seawater. *IEEE Transactions on Antennas and Propagation* 52: 2843–2849.
- [28] Chen H, Qi H and Zhang X. (2008). Research of pipeline robot tracing and localization technology based on ELFEP communication. *IEEE International Symposium on Industrial Electronics*, 30 June–2 July, Cambridge, MA, 1300–1305.
- [29] Nautic Expo. (2012). Available at <http://www.nauticexpo.com/cat/oceanography-and-pollution-response/auv-autonomous-underwater-vehicle-LY-1673.html>, last accessed <10 September 2024>.
- [30] Kato N, Kojima J, Kato Y, Matumoto S and Asakawa K. (1998). Optimization of configuration of autonomous underwater vehicle for inspection of underwater cables. *Robotics and Automation, 1998. Proceedings. 1998 IEEE International Conference 2*: 1045–1050.
- [31] Kojima J. (2003). Cable tracking by autonomous underwater vehicle. *Scientific Use of Submarine Cables and Related Technologies, 2003. The 3rd International Workshop*, 25–27 June, Tokyo, 171–174.
- [32] Takagi S, Kojima J and Asakawa K. (1996). DC cable sensors for locating underwater telecommunication cables. *OCEANS 96 MTS/IEEE Conference Proceedings. The Coastal Ocean – Prospects for the 21st Century*. 23–26 Sept, Fort Lauderdale, FL, 339–344.
- [33] Grzegorzczak TM, Barrowes BE, Shubitidze F, Fernandez JP and O'Neill K. (2011). Simultaneous identification of multiple unexploded ordnance using electromagnetic induction sensors. *IEEE Transactions on Geoscience and Remote Sensing* 49: 2507–2517.
- [34] Clem TR and Lopes JL. (2003). Progress in the development of buried minehunting systems. *Oceans 2003. Celebrating the Past . . . Teaming Toward the Future (IEEE Cat. No.03CH37492)* 1: 500–511.
- [35] Gadomski, A.M., Bologna, S., Di Costanzo, G., Perini, A., Schaerf M. Towards intelligent decision support systems for emergency managers: the IDA approach. *International Journal of Risk Assessment and Management*, 2001 Vol.2 No.3/4, pp. 224-242. DOI: 10.1504/IJRAM.2001.001507.
- [36] Tang, K.H.D.; Md Dawal, S.Z.; Olugu, E.U. A review of the offshore oil and gas safety indices. *Saf. Sci.* 2018, 109, 344–352. doi: 10.1016/j.ssci.2018.06.018.
- [37] Sternlicht DD, Harbaugh JK, Shah AK, Webb ML and Holtzapple R. (2006). Buried object classification using a sediment volume imaging SAS and electromagnetic gradiometer. *OCEANS 2006*, 18–21 Sept, Boston, MA, 1–6.
- [38] Dudchenko, S., Tymochko, O., Makarchuk, D. & Golovan, A., 30 Apr 2024, Application of fuzzy cellular automata to optimize a vessel route considering the forecasted hydrometeorological conditions. In: *Eastern-European Journal of Enterprise Technologies*. 2, 3 (128), p. 28-37. DOI: <https://doi.org/10.15587/1729-4061.2024.302876>
- [39] Madjid Tavana & Brian S. Bourgeois. A multiple criteria decision support system for autonomous underwater vehicle mission planning and control. *Int. J. Operational Research*, Vol. 7, No. 2, 2010. 216-239 pp.
- [40] Dissanayake, G., Newman, P., Clark, S., Durrant-Whyte, H.F. and Csorba, M. (2001) 'A solution to the simultaneous localisation and map building (slam) problem', *IEEE Transactions of Robotics and Automation*, Vol. 17, pp.329–241.
- [41] Zhang, Q.R. (2006) 'A hierarchical global path planning approach for AUV based on genetic algorithm', Paper presented in the Proceedings of the IEEE International Conference on Mechatronics and Automation, pp.1745–1750.
- [42] Aamodt, A. and Plaza, E. (1994). Case-based reasoning: foundational issues, methodological variations and system approaches. *Artificial Intelligence Communications*, J., IOS Press, Vol. 7, No. 1, pp. 39–59.

Information about authors.



Tymochko Oleksandr, Doctor of Technical Sciences, Professor, Head of the Department Flight Academy of the National Aviation University, area of scientific interests: decision support systems, motion control, automation, E-mail: tymochko.alex@gmail.com
 ORCID: <http://orcid.org/0000-0002-4154-7876>
 ID Scopus: 56462977100



Tymoshchuk Olena, Doctor of Technical Sciences, Professor, Department of Navigation and Ship Management, State University of Infrastructure and Technologies, area of scientific interests: navigation, E-mail: mnielena7@gmail.com
 ORCID: <https://orcid.org/0000-0003-3684-6182>
 ID Scopus: 56784308400



Timochko Oleksandr, PhD in Engineering, QA manager in AFC autofleet control, area of scientific interests: decision support systems, test automation, E-mail: alexander.timochko@gmail.com
 ORCID: <http://orcid.org/0000-0003-0424-0426>



Boiko Svitlana, PhD in River and Maritime Transport, Department of ship power plants, auxiliary mechanisms of ships and their operation, SUIT, area of scientific interests: navigation, E-mail: kunaj11@ukr.net
<https://orcid.org/0000-0003-3518-2724>



Mazhara Ihor, PhD, Associate Professor of Department, Ivan Kozhedub Kharkiv National Air Force University, area of scientific interests: navigation, E-mail: i_mazhara@ukr.net,
 ORCID: 0000-0001-7986-4992



Hannoshina Iryna, Ph.D. in navigation and motion control, department of navigation and ship management SUIT, field of scientific interests: navigation, E-mail: iramsu2021@ukr.net
 ORCID: 0000-0001-5810-2462
 ID Scopus: 57216296971



Shapran Yuliya, PhD in Engineering, Department of Natural and Technical Support of Water Transport Activities, State University of Infrastructure and Technologies, area of scientific interests: navigation, E-mail: olilia2007@ukr.net
 ORCID: 0000-0002-0229-2428