

ON THE USE OF REFERENCE NOTES FOR KNOWLEDGE CONSOLIDATION

Mariana COJOCARU & Olga SUGAC

Technical University of Moldova

Abstract: *The present study is an attempt to implement new forms of didactic material submission in the engineering disciplines teaching. The first step was the analysis of existing modern technologies of information submission in compressed form. It has been compared the advantages and disadvantages, and the limitations of each of the didactic materials visualization technology. As a result, we have chosen reference notes as information submission technology, mainly because of the opportunity to use all the possible types of information submission such as graphics, equations, schemes, figures, etc. As confirmation of the targeted technology implementation, we have proposed the reference notes sheet for one subject from the engineering curriculum. The completed or partially completed reference notes, can serve for training of the students, and for assessment of their knowledge as well.*

Keywords: *knowledge, reference notes, visualization, supporting signs, images.*

1. INTRODUCTION

In the era of information saturation the problem of knowledge configuration acquires a big importance. In these conditions, "compression" and visualization of learning information is of urgent need.

A.P Luria, investigating the cognitive processes, emphasized "the mind that works by means of sight, speculative" [1]. "Visual" thinking is thinking through the visual operations. In the other words, visual images are not an illustration of the author's thoughts, but the final manifestation of the mind. In comparison with the common use of visual means, the work of "visual" thinking is an activity of mind, that makes possible translation from one language of information presentation to another, understanding of relations and connections between its objects. At the end, the thinking is uniform: if the teacher makes active "visual" thinking of his students, thereby influences their thinking in "whole".

An active possession of visual material is possible only when the objects of thinking are clearly explained by means of image. Sometimes the teachers consider that a simple demonstration of image, depicting a defined object, allows the students to immediately pick up the idea. This is not always justified. The teacher should help the perception, but not by words, by structuring the picture.

Psychological studies confirm that "perception is not the result of a simple dot transfer of image from the receptors to the brain. Looking at a picture, a person groups some of its parts with others, so the picture, as a whole, is perceived as being something definitely organized" [2].

The form of visualization is a subjective education, and everyone is able to create its own image of the provided information and may not always understand the images offered by the teacher.

The American psychologist Rudolf Arnheim, introduced the term of "visual thinking", and his works initiated the modern researches on the role of imaginative phenomena in cognitive activity. As R. Arnheim correctly noted, „perception and thinking need each other, their functions are mutually complementary: perception, without thinking would be useless, thinking without perception nothing would be reflect about" [2].

Active perception of the signs educational information requires a special organization, considered methods of educational material submission. N. Reznick investigates the features of visual thinking as an example of mathematical disciplines, and emphasizes the following means of visual information presentation:

- drawing – the most rigid geometric means of information presentation method;
- equation method, though can be attributed to visual form, is little associated with visual representations of the students;

- signal and visual means, that is, conventional signs, which allow visual perception of the meaning [2].

2. TECHNOLOGIES OF EDUCATIONAL INFORMATION VISUALIZATION, PRINCIPLES OF THE REFERENCE NOTES DEVELOPMENT

"Compression" and visualization of learning information can be achieved by different methodological techniques, and therefore a variety of knowledge presentation models are known. There is a full open space for a creative initiative of teacher and student. In the university system, the following forms of information submission are the most popular: graph model, production model, logical model, semantic network model, cognitive and graphic elements "Tree" and "Building", frame model, summary diagram and abstract scheme, reference notes or list of reference signs, memory card and metaplan.

As a rule, **graph model**, as a visual learning tool is rarely used in the practice. It can be effectively used in introduction or final lectures.

Production model represents a set of rules or algorithmic instructions for presentation of the solution procedure. As an option of this model can be offered the AOF maps (action-oriented framework) developed by B.Ts. Badmaev. [2]

Logic model is more often used for record of the mathematical axioms and theorems with the use of predicates logic, that allows to reduce the quantity of written-down "signs" in several times.

Semantic network model. It is used for disclosure of the concept volume, which characterizes the subject. As an example of semantic network model can serve the formal and logic technique of information blocks of a big scale reflection. Its varieties are graphs, flow charts and terminological nests.

Cognitive and graphic elements like "Tree" and "Building" are built on flow charts principle, consisting of components, which are arranged, in the studied theory, in the following sequence: base – core - application. Basic concepts, facts and actions modes are presented in base.

Frame model (the frame is a skeleton, a short description of the phenomenon). Usually, the frame consists of several cells, each of which has its own purpose. Examples of frames - tables, matrices, etc.

Diagram summary and abstract scheme can be considered as a special case of the frame model. Her author V.M. Kagan is sure, that the perception of images and phenomena depends on the depth of penetration. [3]

Memory card developed by teachers B.Deporter and M.Henaki approaches a record form to native work of the brain on information perception and its transfer. The symbols and pictures are entered into the memory card for simplification of its memorization. Memory cards can be recommended for the planning or organization of independent activity. For example, the record of instruction can be carried out before the beginning of the students work practices. [4]

Metaplan represents a set of the sign forms (elements) that have a specific purpose. The investigation on the possibility of metaplan use in vocational training belongs to N.E. Erganov. [2]

Reference notes or the list of supporting signs

The concept of reference notes is connected with the name of the teacher innovator V.F. Shatalov. The reference notes is a model of training material content visualization, built on the special principles, in which, ideas in a studied subject are presented in compressed form, and the graphic means for strengthening of the mnemonic effect are used. This method can be called a qualitatively new stage in the systematization of training material; which does not reject, but supplements the general scheme. This method along with others is based on the psychological characteristics of information perception, because it does not comply with a rigid structure of material presentation. In the usual scheme, information is not coded, and the material is presented in a single phrase or complete definitions.

The reference notes strongly differ from the abstract, perhaps, the most detailed one. Making a summary in the traditional way, it is difficult not to give in to temptation to introduce into the abstract more material, to describe in detail each item of the lecture's plan. The reference notes have to be laconic and concise.

The reference notes are an system of supporting signs in form of conditional abstract. The idea of a support is the essence of the abstract. Besides the assimilation of various pieces of information, and various links between them, the symbols, referring to practice and used to specify the abstract training material are introduced in the reference notes.

The font and color show the hierarchy of purposes in terms of importance. Development of the reference notes consists in information compression to the small sizes, using associations, color, fonts, symbols, and the main thing identification. In many cases, episodes and details are an support for assimilation of phenomena and events. They are deposited in the memory as "carriers" of the facts, become signals that cause the event, connected with them, from the memory.

According to V.F. Shatalov, the main requirements for the compilation of the reference notes, are: laconism, unification, autonomy of blocks, the use of habitual associations and stereotypes, otherness and simplicity.

Supporting signs in the V.F.Shatalov' system is the tool for visualization, which plays an important role. According to the specifics of learning material, the material, studied at lecture (the main concepts, formulas, graphs) is modeled in the supporting signs. The supporting signs include specification means, used in narration of a theoretical abstract material: concrete figures, signs, keywords, short phrases, etc..

The supporting signs are syllables, words, letters, numbers, rules and formulas, and many other things. Millions of supporting signs are saved in the persons memory, which help in the reconstruction of assimilated information. Information can be coded in abbreviation, proverbs that relate to the mnemonic form of the information coding. Profitability and the nature of suddenness are the principles on which the supporting signs are based. But there are also others, for example the principle of association. In a large numbers of methodical brochures which contain the supporting signs for various disciplines can be met unexpected words and phrases. Each of those signs contains information that conduct to data reconstruction. It is stored for all life.

To the creative finds of practitioners teachers can be attributed the three-stage reference notes, which allow to carry out the differentiated training. The first step is the most comprehensive reference notes, with the short summary of its constituents; the second stage – the associative reference notes; the third one – the short plan of the answer in basic signals [1].

A generalized scheme of the organization and presentation of educational material, as a rule, includes three levels, interdependent and closely linked:

- a set of previously studied educational elements;
- the main content of the purposeful activity of the students, the basic teaching elements;
- educational material elements, that should be the main, and anticipates a part of future material.

The first and third units are minor, but they constitute the main background for the basic material of the second link learning.

Thereby, the learning is conducted, based on the past and the future, taking into account the three regularities of our memory (operative, short-term and long-term one). The technology of the educational information visualization allows maximally take into consideration this regularity.

For studying the subject «Technology of garments» by the students of the speciality «Clothes and Knitwear Technology», the authors of the article has made the generalization of the reference notes, in which connection between the main concepts of one subject are shown. Since the subject of the studied discipline is the technological process of various garments manufacturing, the basic information is coded in the garment assembly schemes, the name of operations and recommended specialized equipment is provided in text (figure 1).

In the assembly schemes there is no numbering of the technological operations performance sequence and this can serve as a task for independent work of the student in auditorium or out of it. The practical experience of the authors shows that at the intensive work with the reference notes some logical "connections" remain unclear for students. Filling the "emptiness" is possible with additional cards.

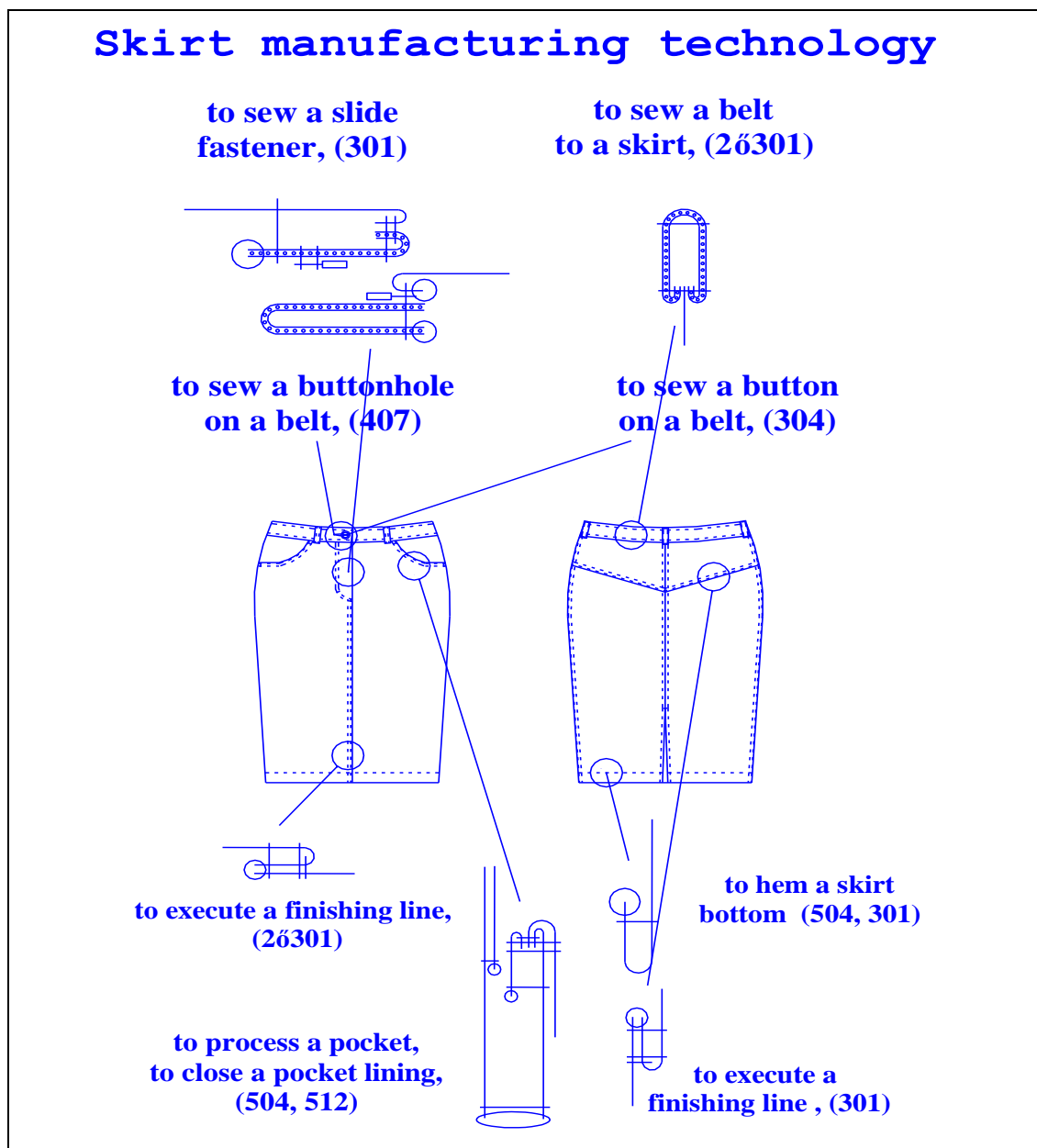

Figure 1: The reference notes for the subject „Skirt manufacturing technology”

3. CONCLUSION

Finally, it is concluded that the training model developed by Shatalov V. F. answers entirely to criteria of manufacturability, conceptuality and systematicity. The practical experience of many teachers speaks about reproduction and viability of this training technology. Conclusions of the authors are that, efficiency of this model is high, because of the better assimilation of educational information in comparison with the traditional models of knowledge presentation.

4. REFERENCES

- [1] Badmaev B.Ț.: *Psihologhia i metodica usckorennoġo obucenia*. – M.: Gumanit. izd. Ńentr VLADOS, 1998.
- [2] Reznic N.A.: *Tehnologhia vizualinogo miřlenia// řcolinŃe tehnologhii*. – 2000. - № 4. pp. 127-141.
- [3] Cagan V.M. *Conspect-shema v optimizatŃii obucenia spetzialinim tehniceschim disciplinam*.-Ircutsc Izd-vo Ircut. Un-ta,- 128 pp.
- [4] DeporŃer B.; Henaki M.: *Kvantovoe obucenie: RazbudŃte speařcevo v vas ghenia!* – Mn.: OOO ”Popurri”, 1998.
- [5] Rudolf Arnheim., *Art and Visual Perception: a psychology of the Creative Eye*, University of California Press, 1954. – 485 pp.

Corresponding author

Mariana COJOCARU
Department of Clothes and Knitwear Technology
Faculty: Textile Industry
Technical University of Moldova
168, bd. Ștefan cel Mare
MD 2004, Chișinău, R.Moldova
E-mail: marianacojocaru@mail.ru

Co-author

Olga SUGAC
Department of Clothes and Knitwear Technology
Faculty: Textile Industry
Technical University of Moldova
168, bd. Ștefan cel Mare
MD 2004, Chișinău, R.Moldova
E-mail: olgasp@list.ru