

Polar – Coordinates Impedancemeter with Simulated Resonance

Nastas V.

Technical University of Moldova
Chisinau, Moldova
v_nastas@yahoo.com

Abstract – Paper contains the analysis of two types of metrological polar - coordinate impedance simulators: with current control and with voltage control, and also of impedance meters realized on their basis. The synthesis of the impedance simulators circuits is considered, the stability study is carried out and the conditions of their optimal application in resonance meters of impedance components are defined. The structures of polar - coordinate impedance meters on the basis of series and parallel circuits with simulated resonance are designed and the optimal algorithm of their equilibration at measurement of impedance with any character of components: active, reactive or complex is offered. The offered devices have a high exactitude and simplicity of practical realization and are suitable for application both in simple and cheap automatic impedance meters, and in meters of a high exactitude.)

Index Terms – Impedance measurement, simulated resonance method, polar – coordinates impedance simulator.

I. INTRODUCTION

Application of simulated resonance method for impedance components measurement allows to achieve a high exactitude of measurements and to simplify the practical realization of meters and measurements algorithms [1]. The practical implementation of method is possible in the series or parallel resonant measuring circuits (RMC) with a current or voltage measuring sources supplying. The equilibration of measuring circuits is possible by means of quadrature, or extreme null detector in conformity with classical theory of null measuring circuits.

The modern practical implementation of resonance method is based on application of the impedance simulator as the impedance standard, that allows to ensure the possibility of impedance with different character of components measurement : active, reactive or complex [2]. It executes the function of the reference impedance (measure) and there are imposed to it a requirements bound with metrological support of measurements. Among them:

- Low error and high stability of reproduced impedances;
- Possibility of any character impedance reproduction and the separate regulation of the impedance components;
- The known and warranted systematic error;
- Digital control.

In view of it, in further the term “metrological impedance simulator” (MSI) will be used, which most adequate reflects the specificity of this device.

Realization of a method in polar coordinates presents the large practical interest, because in this case as it will be shown, the considerable simplification of measurement algorithm is possible. However, the realization of such impedance meters is impossible without application of MSI ensuring reproduction of reference impedances represented in polar coordinates (P-MSI). The indispensable requirement to them is the separate regulation of the module and phase of the reproduced impedance.

The realization of impedance simulators answering to the aforecited requirements is possible on the basis of operational amplifiers (OA) with negative and positive feedbacks. Due to properties of modern OA, the parameters of reproduced impedances are determined with high exactitude only by feedbacks and do not depend on OA characteristics. The nonideality of OA properties results in an error of reproduced impedances which magnitude can be determinate..

II. IMPEDANCE SIMULATORS

As it is known, on the basis of OA with positive and negative feedbacks the realization of impedance converter with classical structure [3] ensuring reproduction of impedance with aspect (1) and suitable for use in the elementary measuring circuits with simulated resonance as the impedance simulator is possible. Also is known the impedance simulator with ladder structure [4], which is designed for use as reference element in Cartesian coordinates resonant impedance meters.

However, the specified MSI cannot be used for reproduction of impedances represented in polar coordinates and looking like:

$$Z = Z \exp(j\varphi) \quad (1)$$

where: Z – the module of reproduced impedance, φ - its phase. The attempts of using in feed-backs loops of phase shifters with the purpose of reproduced impedance phase change have results in complicated dependence of Z_m from magnitudes ensuring regulation of the module and phase, that makes by their unsuitable for use in polar - coordinate impedance meters because of complicated algorithm of measurement.

To the polar - coordinate MSI (P-MSI), apart from defined above requirements, the following supplementary requirements can be formulated:

- Separate regulation of the module and phase of the reproduced impedance;

- Assurance of necessary resolution and exactitudes of the impedance module and phase regulation ;
- Assurance of control bands for module in limits $Z_{min} \div Z_{max}$ and for phase in limits $0 \div 360^{\circ}$;
- Absolute stability of the circuits at the variation of module and phase of the reproduced impedance in necessary limits.

The method of formal structural synthesis was applied for synthesis of structures of P-MSI obeying to all requirements imposed to them, as initial conditions the necessary transformation algorithms of the information is used .

As is known from the theory of impedance converters [5], on the basis of active elements the realization of two types of MSI is possible:

- The current controlled impedance simulator stable down to a no-load condition (I-MSI) (Fig. 1.a),
- The voltage controlled simulator stable down to a condition of short-circuit (U-MSI) (Fig. 1.b).

The first type of simulator (I-MSI) ensures stability at assurance of a ratio between exterior resistance R_e and reproduced impedance R_m :

$$R_e \gg |R_m| \quad (2)$$

The relationship (2) is valid for active resistances, however, as will be shown further, the similar relationship can be defined and in case of complex character impedances, as it is a consequence of more universal condition of stability of the circuits containing active elements.

For the second type of MSI (U-MSI), the condition of assurance of stability in case of resistances of active character looks like:

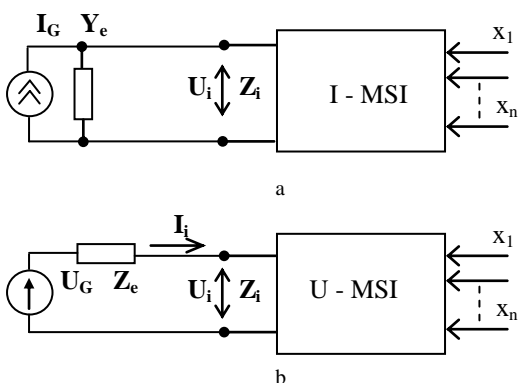

Fig. 1. The external connection of I – MSI (a) and U – MSI (b).

$$R_e \ll |R_m| \quad (3)$$

As well as in case of a condition (3), the condition of assurance of the U-MSI stability further will be defined for the case of complex character impedances.

As have shown the researches, both type of MSI are suitable for use as reference elements in measuring circuits with simulated resonance.

II.A.THE CURRENT CONTROLLED IMPEDANCE SIMULATOR

For synthesis of I-MSI structure, the information conversion algorithm represented in fig. 2.a was used.

The entering current of the circuit I_i under influence of a transfer impedance Z will be transformed to voltage U_1 . On voltage U_1 sequentially influences by magnitude K_m , transforming it in voltage U_2 , and by magnitude K_ϕ transforming it in voltage U_i . The magnitude K_m ensures regulation of the module of voltage without change of its phase, and the magnitude K_ϕ is used for regulation of the phase without action on the module of voltage. The obtained voltage U_i is applied to input of the simulator and jointly with entering current I_i results in reproduction of entering impedance Z_M .

The practical realization of algorithm is executed in MSI, which block diagram is presented in a fig. 2b. The current - voltage converter with a null input resistance and with a conversion factor Z is applied for conversion of entering current I_i in voltage U_1 . Change of the module of voltage U_1 is executed by the programmable amplifier PA with a variable amplification factor K_m , and change of the phase of voltage U_2 - by programmable phase shifter PS. Voltage U_i , bee applied on input of the current - voltage converter results in simulation of an equivalent entering impedance Z_i .

For synthesis of I-MSI structure, the information conversion algorithm represented in fig. 2.a was used.

The entering current of the circuit I_i under influence of a transfer impedance Z will be transformed to voltage U_1 . On voltage U_1 sequentially influences by magnitude K_m , transforming it in voltage U_2 , and by magnitude K_ϕ transforming it in voltage U_i . The magnitude K_m ensures regulation of the module of voltage without change of its phase, and the magnitude K_ϕ is used for regulation of the phase without action on the module of voltage. The obtained voltage U_i is applied to input of the simulator and jointly with entering current I_i results in reproduction of entering impedance Z_M .

The practical realization of algorithm is executed in MSI, which block diagram is presented in a fig. 2b. The current - voltage converter with a null input resistance and with a conversion factor Z is applied for conversion of entering current I_i in voltage U_1 . Change of the module of voltage U_1 is executed by the programmable amplifier PA with a variable amplification factor K_m , and change of the phase of voltage U_2 - by programmable phase shifter PS. Voltage U_i , bee applied on input of the current - voltage converter results in simulation of an equivalent entering impedance Z_i .

The devices implemented on the basis of operational amplifiers (OA) were applied for practical realization of units of the simulator, that ensures a high exactitude of compliance transfer characteristics performances. The variant of the circuit of simulator with presented in a fig. 2.b. structure is presented in fig. 3. On OA A1 an inverting current - voltage converter is realized, the voltage U_1 on which output is determined:

$$U_1 = U_i - R I_i \quad (4)$$

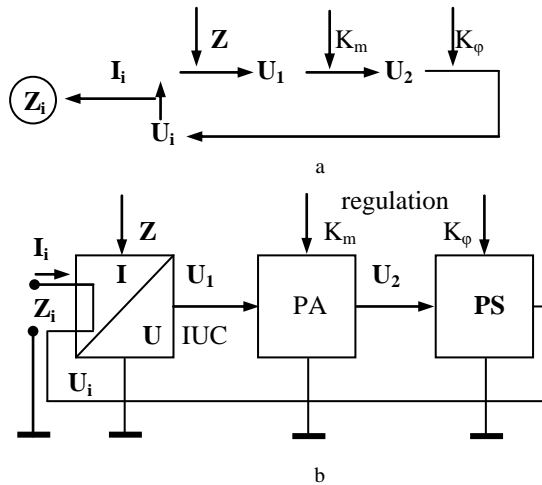

Fig. 2. The conversion algorithm (a) and the structure (b) of I-MSI.

As the programmable amplifier an inverting amplifier on basis of OA A2 is applied, and as the programmable phaser - the unit on basis of OA A3. The voltages on their outputs are equal respectively:

$$U_2 = -U_1 R_2/R_1 = -(U_i - R I_i) R_2/R_1 \quad (5)$$

$$U_i = U_2 \exp(j\varphi) = -(U_i - R I_i) \exp(j\varphi) R_2/R_1 \quad (6)$$

where φ - the phase angle introduced by phaser .

Considering equality to zero of voltage between the inputs of OA in linear operation mode, the input impedance Z_i of the simulator can be determined:

$$Z_i = U_i / I_i = R K_m \exp(j\varphi) / [K_m \exp(j\varphi) - 1] = Z_i \exp(j\varphi_i) \quad (7)$$

where: Z_i , φ_i - respectively, module and phase of impedance Z_i , $K_m = -R_2/R_1$.

However, as follows from expression (7), the dependences of the reproduced impedance module Z_i from parameter K_m of programmable amplifier and of the phase φ_i from phase shift of phaser PS are rather complicated, that does not obey to all requirements to P-MSI defined above. The cause consists at the presence of a common series feedback loop on the current - voltage converter input. To obtain algorithmically correct dependences, the circuit of the simulator was optimized by adding the differential amplifier DA with amplifier factor $K_d = 1$ eliminating the effect of a common feedback in the circuit (Fig. 4). Carried out similar transformations of magnitudes for the optimized circuit, we shall receive the following expression for entering impedance:

$$Z_i = R K_m \exp(j\varphi) = Z_i \exp(j\varphi_i) \quad (8)$$

From obtained expression for Z_i (8) follows, that presented in a fig. 4 circuit of the impedance simulator completely obey to the majority of the requirements formulated above to P-MSI.

The module Z_i and the phase φ_i of simulated impedance are separately controlled by change respectively of amplifier PA amplification factor K_m and of the phaser PS phase angle φ with a required resolution.

II.b. The Voltage Controlled Impedance Simulator

The synthesis of voltage controlled polar coordinate impedance simulator (U - MSI) can be carried out similarly to considered above synthesis of I - MSI.

The information conversion algorithm accepted as an initial condition for synthesized U - MSI is submitted in a fig. 5.b. Entering voltage U_i will be transformed to voltage U_1 under action of a regulated real transmission factor K_m and further, under action of a conversion factor K_F changing only the phase, will be converted in voltage U_2 . The obtained voltage U_2 , converted in the current I_i , is entered to the input of the converter. The current I_i , jointly with entering voltage U_i results in simulation of an input impedance Z_i , or input admittance Y_i .

For practical implementation of aforecited algorithm of information conversion the block diagram represented in the fig. 5.b was submitted. For elimination the influence of the programmable amplifier PA input impedance on the simulated impedance the repeater of voltage is applied, for realization of the conversion factor K_m - programmed amplifier PA, the voltage U_1 on which output is equal:

$$U_1 = K_m U_i \quad (9)$$

The programmable phaser PS will transform voltage U_1 to voltage U_2 , entering the phase shift φ :

$$U_2 = U_1 \exp(j\varphi) \quad (10)$$

The current - voltage converter UIC with transfer conductance G will transform the voltage U_2 to a current I_i flowing past through entering terminals of the simulator and exterior impedance attached to them:

$$I_i = G U_2 \quad (11)$$

The simulated input impedance Z_i is determined:

$$Z_i = U_i / I_i = (K_m)^{-1} G^{-1} \exp(-j\varphi) \quad (12)$$

For presented U - MSI it is sometimes expedient to consider the entering admittance Y_i :

$$Y_i = (Z_i)^{-1} = G K_m \exp(j\varphi) \quad (13)$$

The practical circuit realized on the basis of the considered block diagram is submitted in a fig. 6. The units of the circuit represent the standard circuits realized on the basis of OA, that ensures their high performances.

Having executed for this circuit the transformation of magnitudes agrees (9) - (13), we will found the following expressions for entering impedance and entering admittance:

$$Z_i = (K_m)^{-1} R_1 \exp(-j\varphi) \quad (14)$$

$$Y_i = (R_1)^{-1} K_m \exp(j\varphi) \quad (15)$$

As follows from (14) and (15), the module and phase of an simulated impedance have separate regulation.

Presented in a fig. 6 the U - MSI circuit are only a variant of practical implementation of information conversion algorithm (Fig. 5.a). Depending on the concrete requirements at practical realization of the measuring circuits, other variants of U - MSI are possible also.

From expression (14) for simulated input impedance of U - MSI, similarly to a case of I - MSI, follows that its module Z_i and phase φ_i have separate independent regulations by change respectively of amplification factor of the programmable amplifier K_m and of the phase of the programmable phase shifter φ .

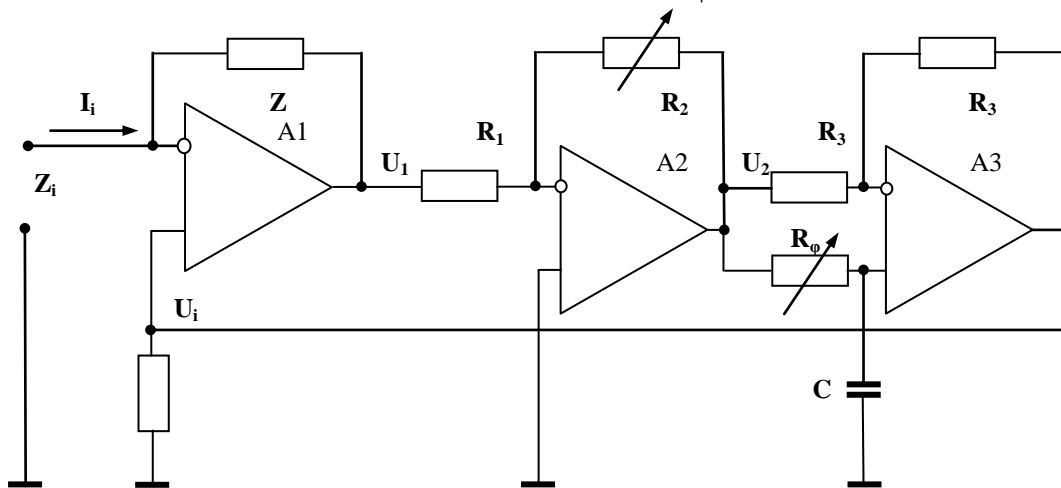

Fig. 3. The real circuit of I – MSI executed by structure on fig. 2, b.

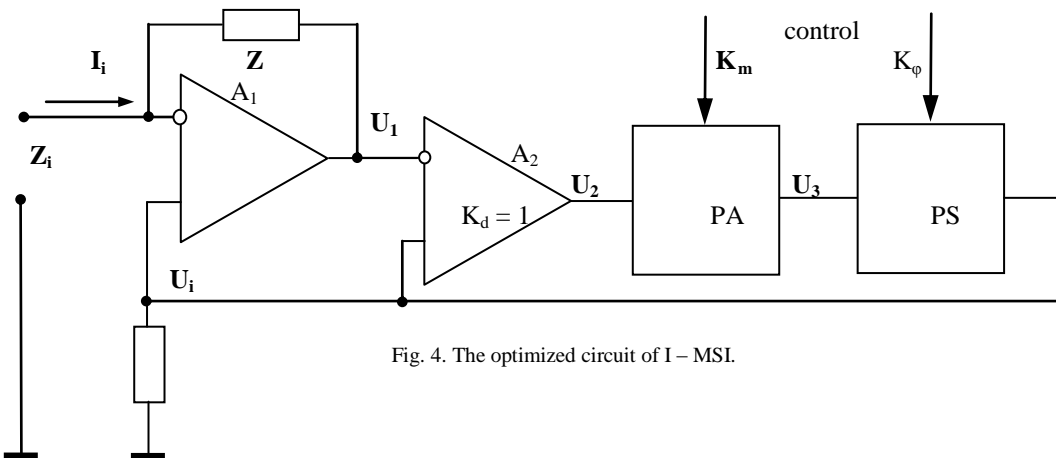

Fig. 4. The optimized circuit of I – MSI.

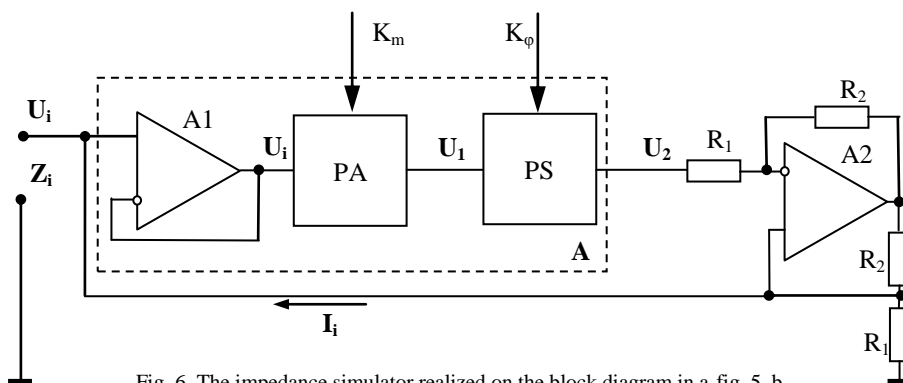

Fig. 6. The impedance simulator realized on the block diagram in a fig. 5, b.

III. STABILITY OF IMPEDANCE SIMULATORS

The problem of the MSI stability is rather important and requires a complex analysis. As in the MSI circuits there is a combined variable feedback, it is necessary to consider three types of stability:

- Stability on a direct current,
- Stability on high frequencies,
- Functional stability.

The stability on a direct current can be interrupted because of appearance of trigger effect [3] at excess of depth of a positive feedback above negative. To ensure absolute stability on a direct current it is necessary to ensure a negative character of a common feedback at variation of parameters of the circuit and of exterior resistance in all operating range. Obviously, for the considered circuit this condition will be executed when the summary transfer factor on a direct current through the common feedback loop $K_{0\text{summ}}$ is negative. It is achieved by combination of inverting and noninverting connection on a direct current of all circuit units

The stability on high frequencies is ensured by correct frequency correction of OA characteristic in all circuit units considering the MSI structure as a multisection amplifier with common feedback [3].

The functional stability of MSI represents a separate question. On the condition of functional stability render influence the following factors:

- Type of MSI;
- Values of the module and phase of simulated impedance;
- Character and value of the equivalent external impedance connected to terminals of MSI.

Thus, the condition of functional stability should be determined for each type of MSI separately, in view of control bands of components of simulated impedance and parameters of the measuring circuit in which it is applied.

For estimation of stability conditions, we shall take advantage of Nyquist criterion in application to the circuits containing operational amplifiers [3]. As is known, the circuits with feedbacks save stability if the critical point $(-1, +j0)$ is located to the left of the hodograph of the transfer characteristic on the loop of the circuit feedback at frequency change from $f = 0$ up to $f = \infty$. Thus, for estimate the stability conditions for the circuits according to Nyquist criterion, it is necessary to determine its loop gain factor βA and to examine it in neighborhood of critical point $(-1, +j0)$ in coordinates $\text{Re}(\beta A)$, $\text{Im}(\beta A)$. Obviously, the condition of absolute stability of the circuit can be defined [3]:

$$\text{Re}(\beta A) > -1 \quad (15)$$

where β – the feedback unit transmission factor, A – the basic unit transmission factor.

Let us estimate the stability condition of the current controlled impedance simulator. For this purpose is used the represented in a fig. 7 I – MSI equivalent circuit. For simplification the analysis, the direct transmission unit consists on the current - voltage converter implemented on OA A1 and the equivalent differential amplifier with the gain factor A which includes the differential amplifier DA, the programmable amplifier PA and the programmable phase shifter PS. Its gain factor A is:

$$A = K_d K_m K_\varphi = K_m \exp(j\varphi) \quad (16)$$

where K_d , K_m , K_φ - transmission factors of respective links and K_d , $K_m = 1$. As all links of the circuit are included in a direct transmission unit, the link of feedback has the transfer factor $\beta = 1$. For determination the transfer factor on feedback loop, we shall break it between the phaser output and the direct input of OA A1. The loop transfer function H_{24} :

$$H_{24} = U_o / U_i = A Z / Z_e = (Z / Z_e) K_m \exp(j\varphi) \quad (17)$$

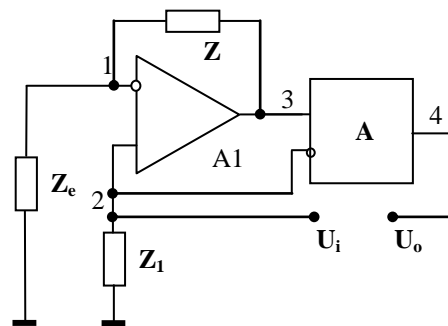

Fig. 7. The model of I – MSI for stability analysis.

Considering $Z \equiv R$, the real part of (17):

$$\text{Re}(H_{24}) = (R K_m / |Z_e|) \cos(\varphi - \varphi_e) \quad (18)$$

The Nyquist criterion (15) for function (17) looks like:

$$(R K_m / |Z_e|) \cos(\varphi - \varphi_e) > -1 \quad (19)$$

For ensure the stability of the circuit in all range of simulated impedance phase variation $\varphi = 0 - 360^\circ$, we consider the most critical case when $\cos(\varphi - \varphi_e) = -1$. Then the condition of stability (19) will take the aspect:

$$|Z_e| > R K_m \quad (20)$$

As follows from above-stated, the offered circuit of I – MSI maintains stability at variations of regulating module parameter K_m and regulating phase parameter φ of simulated impedance in limits:

$$K_m = 0 \div |Z_e| / R, \quad (21a)$$

$$\varphi = 0 - 360^\circ \quad (21b)$$

The carried out study of I - MSI stability allows to make the conclusion, that the current controlled polar - coordinate impedance simulator maintain absolute functional stability at its application in the series resonance measuring circuits [1], where the condition (26) is ensured automatically.

For the voltage controlled impedance simulator (U - MSI) the condition of stability can be determined similarly. In fig. 8 the circuit of simulator containing a direct transmission link with a transfer factor A and the feedback link with transfer factor β is submitted. For modeling the condition of external load, the equivalent impedance of extern circuit Z_e is connected to the simulator input. The link of a direct transmission contains concatenation of repeater with transmission factor $K = 1$, the programmable amplifier with transfer factor K_{PA} and the programmable phaser with transfer factor $K_{P\phi} = 1 \exp(j\varphi)$. The feedback link consists on voltage - current converter based on OA A_2

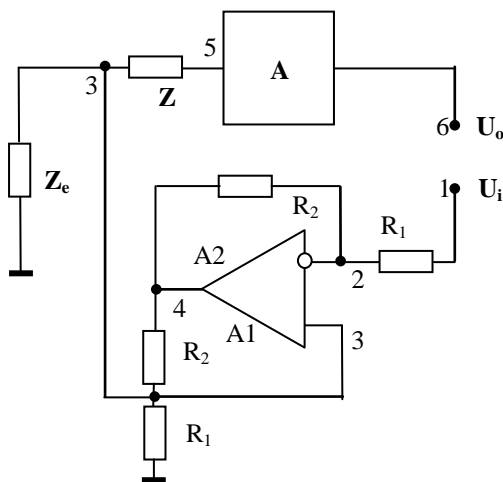

Fig. 8. The model of U – MSI for stability analysis.

Breaking of the feedback loop is executed between the output of direct link A and the input of the voltage – current converter. As follows from the fig. 8, the loop transfer factor βA for the circuit is equal:

$$\beta A = - A Z_e / R_1 = - K_m \exp (j\varphi) Z_e / R_1 \quad (22)$$

The Nyquist stability criterion applied to this circuit:

$$\operatorname{Re} (\beta A) = \operatorname{Re} [- K_m \exp (j\varphi) Z_e / R_1] = - (K_m |Z_e| / R_1) \cos (\varphi + \varphi_e) > - 1 \quad (23)$$

Similarly to previous case, we shall determine the stability condition at variation of the simulated impedance phase in all range of values $0 \div 360^\circ$, for what we shall accept the critical value

$$\cos (\varphi + \varphi_e) = 1 \quad \therefore K_m |Z_e| / R_1 > - 1 \quad (24)$$

Solving of (24) results in the following condition of U - MSI absolute stability:

$$|Z_e| < R_1 / K_m \quad (25)$$

As follows from (25), the U - MSI circuit saves stability at variation of the simulated impedance module and phase regulation parameters in limits:

$$K_m = 0 \div R_1 / |Z_e|, \quad (26a)$$

$$\varphi = 0 \div 360^\circ \quad (26b)$$

The carried out stability study of U - MSI allows to make a conclusion, that the voltage controlled polar - coordinate impedance simulator maintain absolute functional stability at its application in the parallel resonance measuring circuits [1], where the condition (26) is ensured automatically. Its application in other circuits with condition of respect the condition of stability (26) also is possible

IV. POLAR COORDINATES Z - METER

Compared with Cartesian - coordinate, the polar - coordinate impedance meters have the following advantages:

- simple equilibration algorithm of measuring circuit;
- possibility of impedance with any character of components, including negative measurement;
- possibility of representation of result in polar or in the Cartesian coordinates;
- possibility of representation of measured impedance as the series or parallel equivalent circuit;
- simplicity of measurement operation automation.

The polar - coordinate impedance simulators [6] application as reference elements in the resonance measuring circuits allows to create qualitatively new types of Z - meters, distinguished by simplicity of practical realizations and high exactitude of measurement. For this purpose both series, and parallel resonance circuits (Fig. 10) can be used.

In the series RMC (Fig.10,a) the measuring circuit is supply by the stable current I_G of the generator G. The impedance simulator I - MSI reproduces on its output poles an reference impedance Z_i the value and the character of wich is determined by the quantities q_m, q_φ controlling its module and faze after dependence (8).The sum of voltage on measured (Z_x) and reference (Z_i) impedances U_{de} form the signal of unbalance fixed by the null detector FNO [7].

The same process takes place in parallel resonant circuit (Fig. 10.b). Owing to dual correlation of magnitudes and processes in series and in parallel resonance circuits, the structure of the information conversion in these circuits is identical, with that only of difference, that the series resonance is substituted by a current resonance, and as a unbalance signal of a null detector the current I_{de} flowing past through the resonance system is used.

In fig. 9, a is presented a polar coordinates Z-meter implemented on the basis of a series resonance circuit. Except of the impedance simulator, it also contains the generator of measuring signal G, null-indicator NO, measured impedance Z_x and the command unit. The unbalance signal U_{de} contains information about the state of measuring process. On its value the command unit realizes regulation of the simulated impedance modulus Z and phase φ up to achievement of the state of complete equilibrium in measuring circuit.

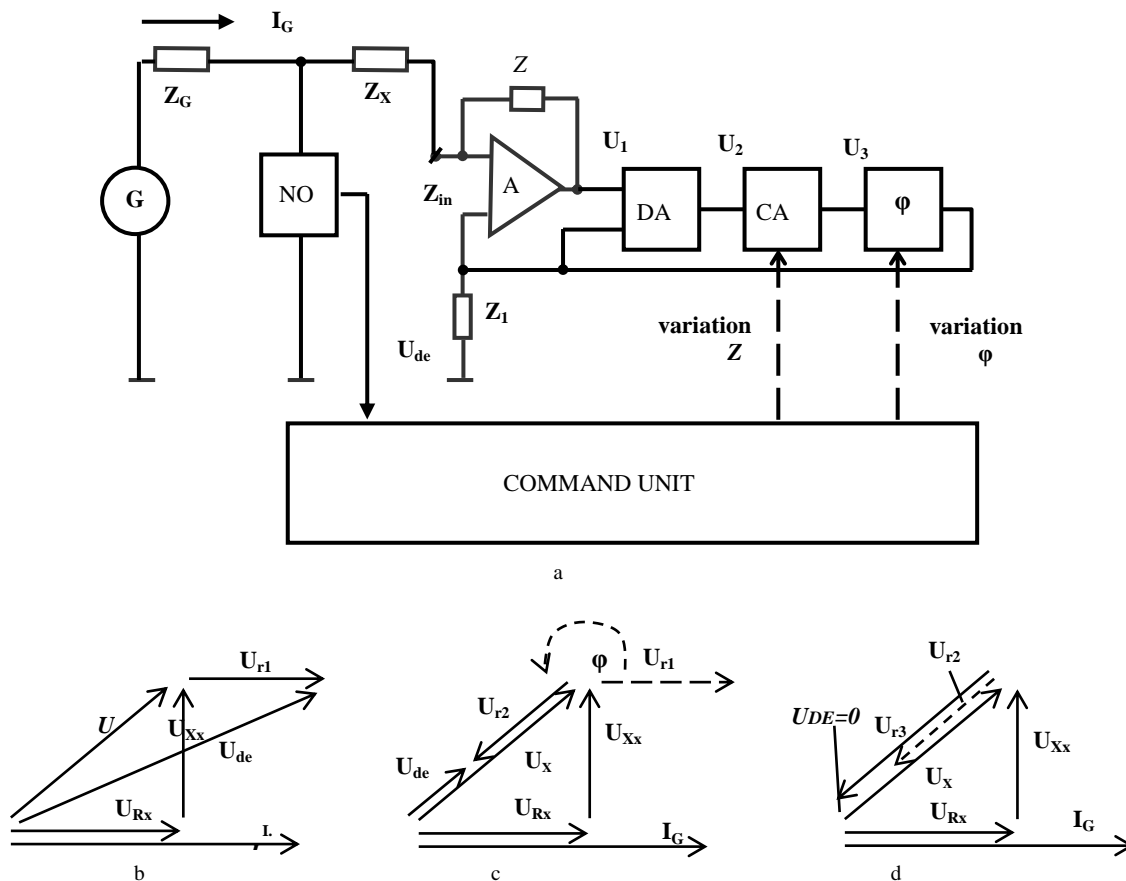

Fig. 9. Polar – coordinates impedance meter on basis of series resonant circuit
 a) The structure of impedance simulator, b – d) the diagram of equilibration process:
 b – creation of trial reference impedance, c – rotation of reference impedance vector on angle φ ,
 d – variation of reference impedance module.

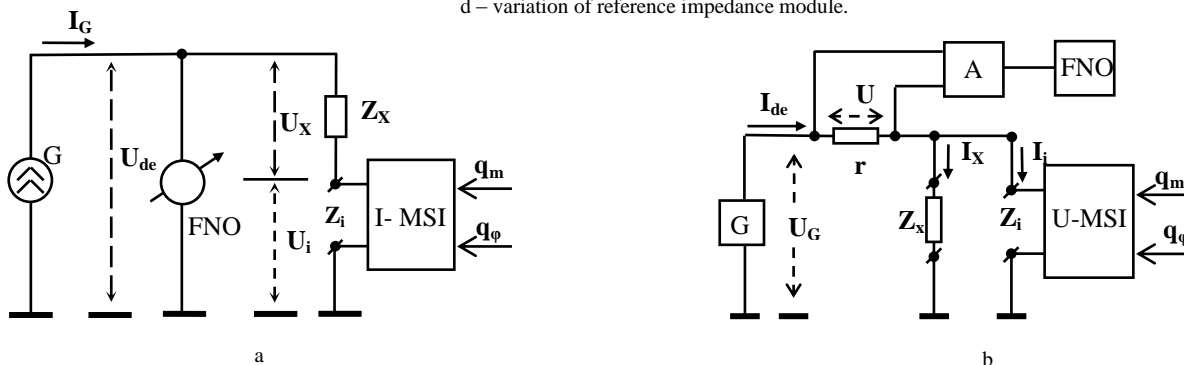

Fig. 10. The series (a) and the parallel (b) RMC

The process of measurement consists on three operations. At the first stage (Fig. 9,b) an arbitrary trial vector of simulated impedance is created. The input signal of null-indicator:

$$U_{de} = I \cdot (Z_x + Z_r) = U_x + U_{r1} \quad (27)$$

At the second step (Fig. 9,c) the reference impedance vector Z_{r1} is rotated on angle φ , up to achievement of the condition $U_{de} = \min$. After that it takes a position Z_{r2} . The finite operation (Fig. 10,d) consists in regulation of the reference impedance modulus up to achievement the state of complete equilibrium in measuring circuit. To this state there corresponds the condition $U_{de} = 0$. The result of measurement

$$R_x = Z_r \cos \varphi, \quad X_x = Z_r \sin \varphi \quad (28)$$

Thus, the offered method ensures measurement of both impedance components with a high accuracy characteristic for null methods of measurement and, as contrasted to well known bridge method, has a considerable simplicity of practical implementation and algorithm of measurement

CONCLUSIONS

In polar - coordinate impedance meters with simulated resonance as reference element the polar - coordinate impedance simulators it is necessary to use.

By algorithmic synthesis, having accepted as a basis the necessary information conversion structure, the current controlled and the voltage controlled impedance simulators suitable for use in series and in parallel measuring circuits are synthesized. The simulators have separate control of simulated impedance module and phase and ensure reproduction of any character impedance without use of variable

reactive elements and without commutations in the circuit.

As follows from the stability analysis, current controlled impedance simulator save absolute stability in the series resonance circuit with signal supply from a current source, the voltage controlled - in the parallel circuit with signal supply from the voltage source.

On the basis of presented impedance simulators the polar - coordinate resonance impedance meter having an simple measurement algorithm and high exactitude is developed. The equilibration process of a meter consists from three operations and is completely automatized.

REFERENCES

- [1] V. Nastas, M. Scînteianu, “The impedance measurement by method of simulated resonance” *Proceedings of the 8th International Conference OPTIM 2002*, pp. 683-688, Braşov, 2002
- [2] V. Nastas, , “Impedance simulators with variable character for metrology” *Moldavian Journal of the Physical Sciences*, Vol. 1, No. 3, 2002, pp. 28 - 31, Academy of Sciences of Republic Moldova, Chişinău, 2002
- [3] J. Dostal “Operational amplifiers”, ELSEVIER SPC, New York, 1981.
- [4] V. Nastas, “Synthesis of impedance simulators for resonant measuring circuits”. *Meridian ingineresc*, nr. 4, 2002, pp. 83-88, ”TEHNICA-INFO” , Chişinău.
- [5] F. Bening, „Negative viderstande in elektronischen schaltungen”, VEB VERLAG TECHNIC, Berlin, 19
- [6] Pat. MD 420Y . Polar- coordinates impedance simulator.. Author: V. Nastas, Chişinău, 2012.04.30
- [7] Pat. MD 392Y . Method of measuring impedance components. Author: V. Nastas, Chişinău, 2010.06.30