



TOPOLOGICAL MODELLING OF THE METROLOGICAL IMPEDANCE SIMULATORS

Vitalie NASTAS, Pavel NICOLAEV

Technical Universty of Moldova, vitalienastas@gmail.com

Abstract – The given research represents an analysis of impedance simulators circuits principle of work by means of the oriented graphs method. The veracity of the obtained results is confirmed by comparing the latter with those obtained by computer simulating in the Multisim program.

Keywords: Metrological impedance simulator, oriented graph, simulated impedance, topological modelling.

1. INTRODUCTION

The metrological impedance simulators (MIS) in Cartesian coordinates represent some circuits, which ensure the reproduction of reference impedances with a different character, used to measure of impedances [1], [2]. The impedance reproduced by the MIS is expressed in cartesian coordinates ensuring the independent adjustment of active and reactive components. According to the entrance primary value, the MIS can be either current commanded, or voltage commanded.

One of the most efficient instruments of analysing and optimizing the processes in such circuits is the method of oriented graphs.

2. METHODES DE CALCUL DU FLUX LUMINEUX EMIS PAR LES SOURCES ELECTRIQUES DE LUMIERE

For electronic circuits the oriented graph has the form of an arbor, where the nodes correspond to the equations dependent or independent variables, and the links between the variables are represented through branches which join the given knots. The nodes are described by the knot sign, but the branches by orientation and the transfer coefficient [3]. The MIS circuits [1] are composed of levels with linear transfer functions, on the basis of operational amplifiers (OA) with passive elements and don't contain non linear elements.

Figure 1 represents the structure of a MIS circuit commanded in current. It contains the next levels: the

current-to-voltage convertor (OA A_1), the differential amplifier (OA A_2), the first and the second programmable amplifiers (respectively, OA A_3 , A_4), the third and the fourth programmable amplifiers (respectively, AO A_5 , A_6), the phase shifter at 90° (AO A_7) and the summator on the OA A_8 basis. Selection of the value band for the active component adjustment of the impedance Z_i , produced at the entrance pole is carried out with the resistor R_6 , and for the reactive component – with the resistor R_8 .

Adjustment of the reproduced impedance active component in the selected band is carried out by means of the resistor R_{11} , and that of the reactive component - with the resistor R_{14} .

In the oriented graph of the circuit the ideal operational amplifiers graph with infinite amplification factor are used [3].

The figure 2 represents the circuit oriented graph. G_i represents the R_i resistances conductances, $B_i - X_{C1}$ reactance susceptance, δ, ρ respectively represent the R_{11} and R_{14} resistors insertion characteristics in the circuit.

The problem proposed to be solved is to determine the transfer factor from the circuits A point to B point, A node sign being the I_i current, and B node sign being the U_s voltage. To simplify the circuit graph there were carried out transformations in the graphs of all the MIS component blocks according to the transformations rules [4], taking in consideration the components values. The simplified graph (Fig. 3, a) ensures the same function of transfer from point A to point B alike in the initial graph.

To determine the transfer factor between A and B points, which correspond to the MIS entrance poles, the whole graph was reduced to a single branch (Fig 3, b).

The virtual impedance Z_i reproduced by the MIS at the entrance poles can be determined:

$$Z_i = U_s / I_i \quad (1)$$

where U_s is the voltage on the resistance R_s , I_i – the MIS entrance current.

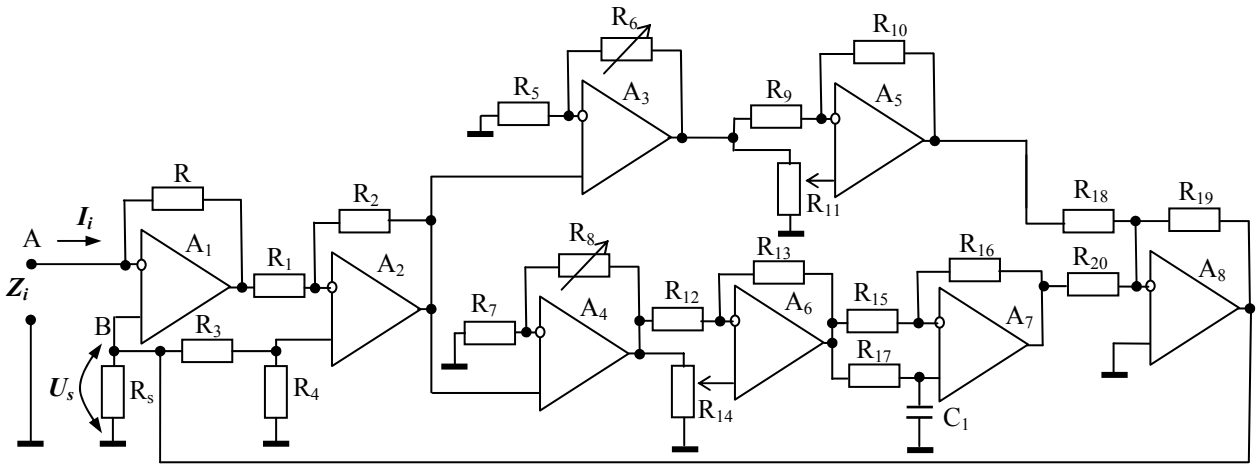

Figure1: The structure of the current – commanded MIS.

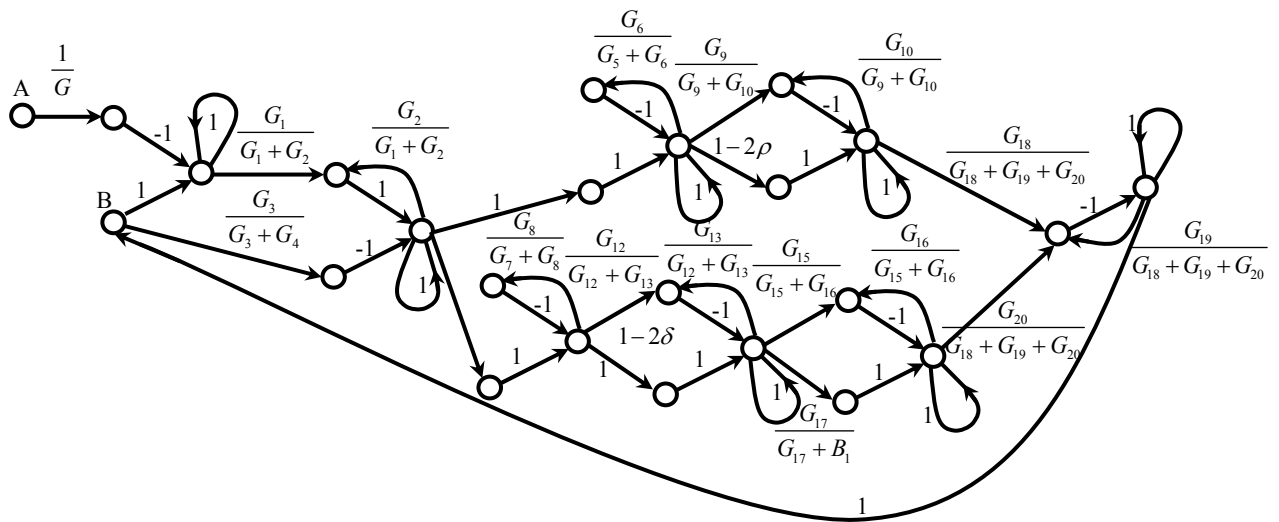

Figure 2:– Graph of the current commanded MIS.

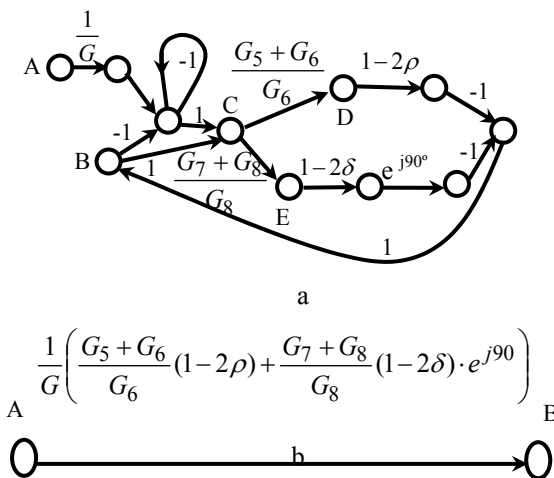

Figure 3: The simplified graph (a) and the final graph (b) for current commanded MIS.

Considering the current I_i as an initial value in A point, and the voltage U_s as the final value in B point, we obtain:

$$U_s = -I_i R [K_1(1 - 2\rho) + K_2(1 - 2\delta) \cdot \exp j90^\circ] \quad (2)$$

where K_1 and K_2 are the transfer factors between C and D points respectively, between C and D (Fig 3, a), determined by the following relations:

$$K_1 = (G_5 + G_6) / G_6 = 1 + R_6 / R_5 \quad (3)$$

$$K_2 = (G_7 + G_8) / G_8 = 1 + R_8 / R_7 \quad (4)$$

Considering relations (1) and (2), the impedance reproduced by the MIS can be determined:

$$Z_i = -R [K_1(1 - 2\rho) + K_2(1 - 2\delta) \cdot \exp j90^\circ] \quad (5)$$

3. MODELING IN MULTISIM

3.1 The series resonant circuit

The veracity of the obtained results of MIS analysis by means of the oriented graph method can be confirmed by comparing the latter with those, obtained in accordance with the classical theory and with those, obtained in result of computer modeling of the circuit. Theoretical study of impedance simulators is possible only including it in the compenence of series, or parallel resonant circuits.

The structure of the series resonant circuit is represented in Fig. 4. The resonant circuit feeds with stable current I_G from the generator G and contains the connected in series measured impedance Z_M and current – commanded impedance simulator MIS.

The voltage U_{de} are used as signal of state of the circuit. In order to balance the resonant circuit, there will be adjusted the reproduced by the MIS impedance components.

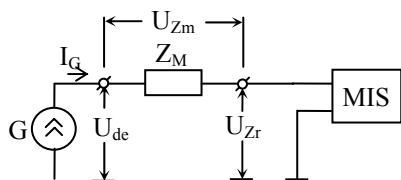

Figure 4: The series resonant circuit.

As a signal of imbalance it serves the voltage U_{de} , and, in order to balance the series resonant circuit will be adjusted the impedance components reproduced by the MIS.

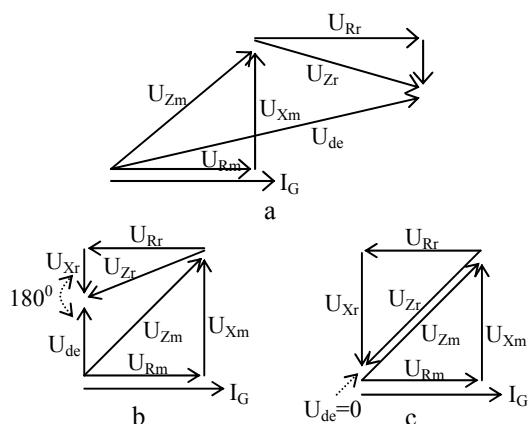

Figure 5: Process of balancing of resonant circuit
 a. – initial stage, b. – balance at the active component,
 c. – balance at the reactive component.

In the process of balancing the series resonant circuit, the phase of the imbalance signal is compared with the phase of the reference signal produced by

converter, whose phase coincides with the phase of current through the resonant circuit.

The balance process consists of two stages (Fig. 5): at the first stage (Fig. 5.b) it is adjusted the impedance active component until it is obtained a 180° dephasing between the imbalance and the reference signals; at the second stage (Fig. 5.c) it is adjusted the impedance reactive component until it is obtained a nul value of the imbalance signal [5].

While balancing the circuit the voltage U_{de} consists:

$$U_{de} = U_{Zm} + U_{Zr} = I_G(Z_M + Z_i) = 0 \quad (6)$$

The measured impedance Z_M and the reference impedance Z_i can be represented in Cartesian coordinates:

$$Z_M = R_M + jX_M \quad (7)$$

$$Z_i = R_i + jX_i \quad (8)$$

From relations (6), (7) and (8) it results:

$$I_G[(R_M + jX_M) + (R_i + jX_i)] = 0 \quad (9)$$

The equation solutions(9) are:

$$R_M = -R_i, \quad X_M = -X_i \quad (10)$$

3.2 MIS modeling in Multisim

In the process of modelling the series resonant circuit in the Multisim program (Fig. 6) it was used as a current generator the voltage generator V1 with a high internal resistance $R_1 = 10 \text{ M}\Omega$. The measured impedance is modelled with the $R_2=1 \text{ k}\Omega$ resistance and the $C_1=5\text{nF}$ capacitance and is connected in series with the V1 generator and the MIS.

The process of balancing consists of the same two stages and it is represented in Fig.7. At B entrance of the oscilloscope it is applied the reference signal from the converter exit (marked by „o”), and at A entrance it is applied the imbalance signal (marked by „x”).

Initially it is modified the active component by adjusting R_{10} and R_{15} potentiometers until it is obtained a 180° dephasing between these signals (fig. 7, a), then at B entrance it is applied the signal from V1 tension generator and it is modified the reactive component by means of R_{12} and R_{18} potentiometers till the imbalance signal reaches the minimal value (fig. 7, b).

The active component of the reproduced impedance can be determined with the next relation:

$$R_i = R_3(R_{10} \text{ c\%/100\%} + 1)[2(100\% - a\%)/100\% - 1]$$

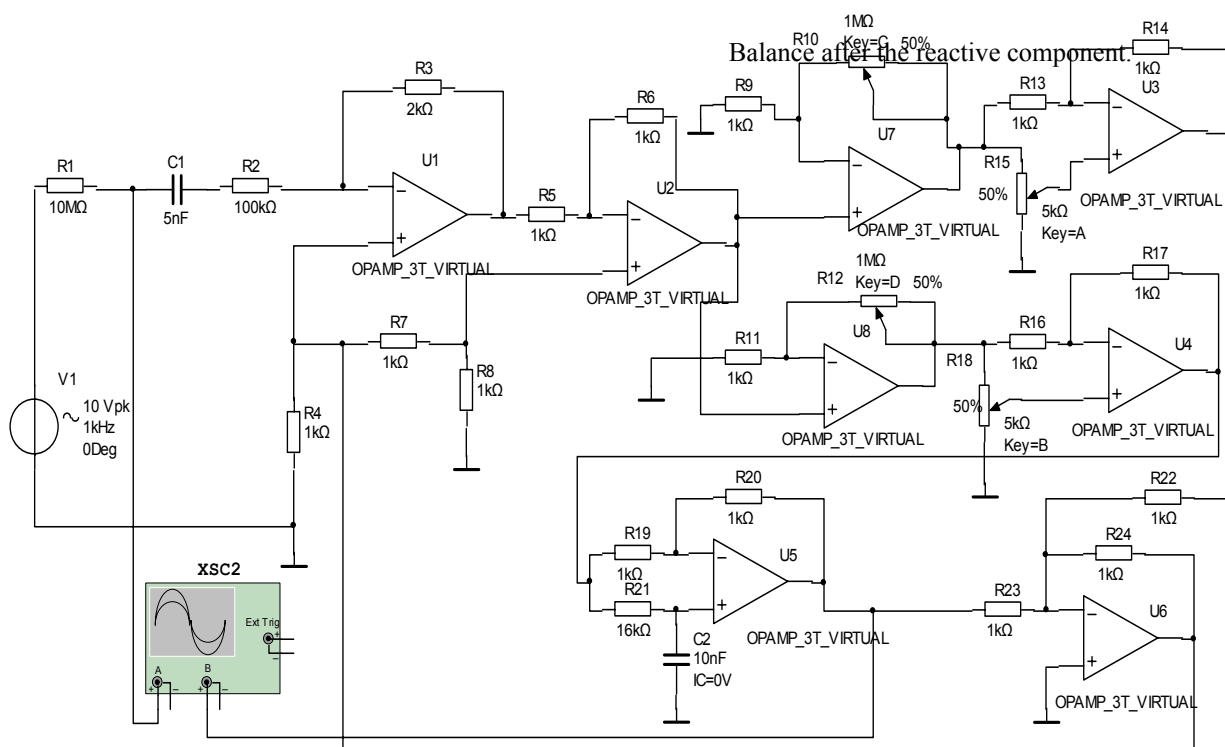
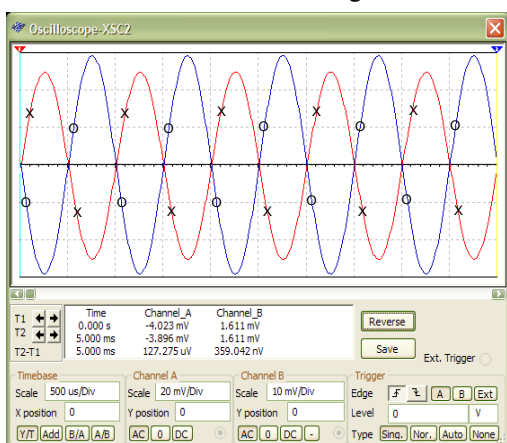
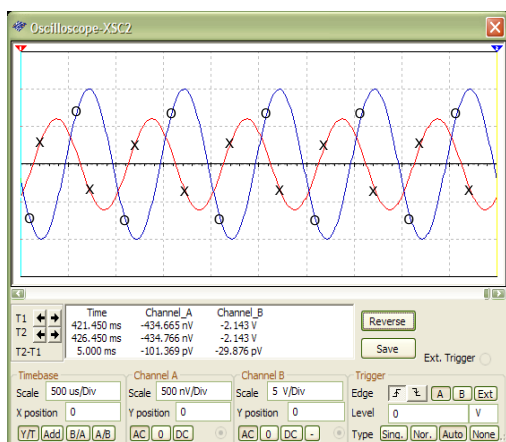

Figure 6: Series resonant circuit modelled in Multisim.



a



b

Figure 7: Series resonant circuit balance modelled in Multisim a. Balance after the active component, b.

where a and c – represent the variation percentage of R_{10} and R_{15} potentiometers. These measurement will have the values $a=76\%$ and $c=10\%$ at the circuit balance after the active component. According to relation (11) it is obtained $R_i=-105,04$ k Ω .

The reactive component of the reproduced impedance is determined with the next relation:

$$X_i = R_3(R_{12} d\%/100\% + 1) [2(100\% - b\%)/100\% - 1]$$

where b and d represent the variation percentage of R_{12} and R_{18} potentiometers.

These values will have the values $b=58\%$ and $d=10\%$ at the circuit complete balance.

According to previous relation it is obtained $X_i = -32,32$ k Ω . According to (8) the impedance reproduced by the simulator will have the next value:

$$Z_i = R_i + jX_i = (-105,04 - j32,32)k\Omega \quad (11)$$

The impedance measured in accordance with C_1 and R_2 values represents :

$$Z_M = R_2 + j/2\pi f C_1 = (100 - j31,847)k\Omega \quad (12)$$

where f is the signal frequency. Relations (11) and (12) entirely confirm the theoretical analysis.

4. CONCLUSIONS

The application of topological modelling in the process of projecting MIS circuits allows to carry out the optimization of their structure as well as the analysis of their characteristics of utilization.

The results obtained at the MIS topological analysis correspond with those obtained at the theoretical analysis [2], and with those obtained by means of computer simulating.

References

- [1] V. Nastas. *Admittance converter*. Patent MD 3111. Publ. BOPI nr. 7, 2006, Chishinau, MD
- [2] V. Nastas, A. Nastas. *Impedance converter*. Patent MD 3154. Publ. BOPI nr. 9, 2006, Chishinau, MD
- [3] Robin J. Wilson, *Introduction to graph theory*, Oliver and Boyd, Edinburgh, 1972.
- [4] Mason S., Zimmermann H., *Electronic circuits, signals and systems*, John Wiley and Sons Inc, New York, 1960.
- [5] V. Nastas, V. Cojocaru. *Method of impedance components measurements* Patent MD 3577. Publ. BOPI nr. 4, 2008, Chishinau, MD.