

## OBJECT SORTING USING COMPUTER VISION TECHNOLOGIES

Alexandru OSADCENCO<sup>1\*</sup>, Vladimir LEADAVSCHI<sup>1</sup>,  
Daniela PALAMARI<sup>1</sup>, Alexandru LATCOVSCHI<sup>1</sup>

<sup>1</sup>Technical University of Moldova, Faculty of Computers, Informatics and Microelectronics, Software Engineering and Automation Department, FAF-182 group, Chişinău, Republic of Moldova

\*Corresponding author: Alexandru Osadcenco, [alexandru.osadcenco@isa.utm.md](mailto:alexandru.osadcenco@isa.utm.md)

**Abstract:** *Newly, all activities conducted routinely in the industry have been increasingly favouring robotic automation. Pick and place robots are a type of technology used in the manufacturing industry to conduct operations of picking objects from a point and moving it to another. The system is built in such a way that it prevents human error, resulting in more accurate work. Pick and place robots are built and deployed in a variety of fields, including the packaging industry, food industry, manufacturing industries, and even surveillance to detect and kill explosives. Moreover, robotic arm prototypes serve as an example for those interested in its programming and kinematics, giving them the freedom to create and upgrade it, due to its several software and hardware interactions.*

**Keywords:** *robotic arm, computer vision, image processing, deep neural network, cloud, tensorflow, degrees of freedom.*

### Introduction

People have been attempting to substitute human labor with machines for several years, as robots are mechanisms that are quicker and more powerful than humans. Robotics is focused on the research, design, and use of robot systems in manufacturing. Generally, robots are used for rather dangerous, repetitive, and unpleasant tasks, such as arc welding, resistance weldings, material handling, loading and unloading, painting, spraying, and other similar functions. Many aspects of robotics are modeled after natural phenomena, [1] the most obvious being the robotic arm, which is built on the basis of a human arm. The technological advancements in the electronic industry have appended machine vision capability to the classic manipulation of objects by picking and placing.

“Picking and placing” objects from a certain point to a destination is one of the most important and common tasks. However, the transfer of heavy materials done manually and for an extended period of time may result in injuries to the operator. Through employing a robot, the operator would no longer be required to bend and lift heavy loads, thus reducing accidents and errors and increasing work performance. The mechanical arm can conduct a wide range of manufacturing tasks in a versatile and cost-effective manner.

### Computer Vision

The goal of image recognition technology is to detect target objects using image processing and pattern recognition theories and methods, define semantic categories for these objects, and mark the specific location of the target object in the image. Image recognition techniques are also useful in a number of applications, including facial recognition for surveillance, image classification in cloud services, and vast visual databases on websites like stock photography websites.

One of the aims of computer vision technology is to extract meaningful knowledge from images. The main focus is to emulate human vision abilities in an electronic environment through processing, analysis, and extraction of information by working on images. Image comprehension is described as the process of extracting symbolic or numeric information from images using methods based on geometry, physics, and statistics [2–4]. Applications that use automatic image processing rely on computer vision as a foundation. Computer vision-based applications include controlling processes, navigation, detecting events, modelling objects or environments. This paper focuses on the robot arm system used to detect plastic bottles that are randomly located in terms of position and orientation.

Many studies have been conducted on the incorporation of computer vision into the functionality of a robot arm. One of these papers [5] describes a learning algorithm that tries to distinguish points from two or more images of an object in order to grab it with a robot arm. The algorithm turned out to have an overall accuracy of 87.8%. In a research done on an autonomous robotic framework that includes a vision system, [6] the robot arm performed autonomous object sorting based on the shape, size, and color of the object. In another study, an educational robotic arm uses a vision system to detect a randomly positioned object, pick it up, and move it to a predefined container [7].

In this paper, a robot arm system is designed to detect and identify plastic bottles, grab them, and move them to a container. A camera is used to capture an image of the objects to be further identified through image processing methods. Then, the coordinates of all detected objects are calculated on the computer and sent to the robot arm. Subsequently, the angles of the robot arm joints are calculated using the obtained coordinates, and the robot arm moves the objects.

### **Object detection model**

The detection of plastic waste, particularly plastic bottles, and its sorting are done with the help of a robotic arm through object detection.

For object detection, we need to use a segment of Neural Network Algorithms preoccupied with computer vision - Convolutional Neural Networks. A Convolutional Neural Network (CNN) is a type of Deep Neural Network (DNN) that is widely used in the field of image analysis and extraction of useful information from the analyzed images. It poses properties very useful for our project, such as object recognition and image position recognition [8]. CNNs are very useful for defining objects in images without a large number of parameters, i.e. they are ideal for recognizing objects with just a few parameters about the target object. CNNs have become the appropriate option even for images with large dimensions, as a result of this function. Storage and retrieval are no longer a problem in the field of computing in the era of big data [8].

Our camera will capture the image once in a  $n$ 'th milliseconds and preprocess this image to detect the current position of the object. Its speed will be enough for the movements made by our robotic hand. Additionally, it will reduce the cost of preprocessing the image constantly.

Our model is based on the TensorFlow library, developed by Google.

TensorFlow is an open source software library, used in many industries for resolving problems regarding Machine Learning and Neural Networks. Companies use TensorFlow because of its portability and compatibility to run on a wide range of devices - from mobile phones to web browsers. One of the most important applications of TensorFlow is its usage in image recognition techniques. This library is used to create an interface for Machine Learning algorithms.

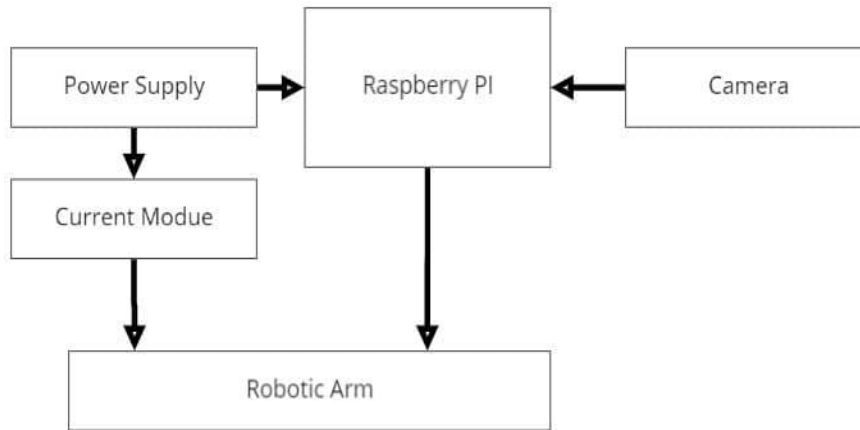

**Figura 1. Proposed System**

For the plastic bottle sorting robotic arm, an appropriate solution is to use a pre-trained TensorFlow Machine Learning model, provided by MIT licence. TensorFlow Object Detection API offers the possibility to run in the Cloud, as the image will be sent to the cloud and will be processed by the model, returning the results to us. The results consist of the object type and its position in the designated space.

**Functionality of Robotic Arm**

The robotic arm attempts to reproduce movement similar to a human arm. It has the base to rotate the arm from 0 degrees to 360 degrees. Like the human hand, the arm consists of the shoulder, elbow, wrist and mechanical gripper to hold the object. A term that’s used for a mechanical system where the number of independent parameters that define its configuration is called DOF (degrees of freedom) [9]. When a robot arm is designed, the DOF is considered and it is related to have the ability to manipulate objects such as pick and place operations. The pick and place mechanical operations is a human controlled based system that detects the object, picks that object from source location and places it at the desired location. The robot arm would have 3 degrees of freedom, because it can move objects by picking them up or down and placing them from one place to another (left or right in this case) [10].

*Table 1*

**Number of degrees for specific DOF**

Degrees of Freedom(DOF)	Degrees
1	180
2	90
3	90

Based on the object detection, the processor sends a signal to the motor driver circuit which drives the motors setup of the robotic arm to grip the object and place it in the pre-allocated location, releases the object and comes back to the original position. The robotic arm links, joints, actuators, sensors and controllers. The links are connected by joints to form an open kinematic chain.

**Conclusions**

Nowadays, the use of robotic arms can require an incredibly complex design or high costs. In this project, we aim to construct a Robotic Arm System using accessible materials, teaching it to successfully pick and place an object from one place to another, characterized by 3 DOF. The

camera appended to it will be sending digital images to the processing TensorFlow model, which is located in the Cloud. This system is adaptable to any sort of camera, utilized as a sensor that captures the image of the object and measures its dimensions after processing the image in TensorFlow. It gives us a low-cost, scalable solution with simplest concepts which saves manual time and work. Another of its advantages is that it can work with any sort of device or in parallel with a few devices.

### References

1. Harish K, Megha D, Shuklambari M, Amit K, Chaitanya K Jambotkar, *Pick and Place Robotic Arm Using Arduino*, International Journal of Science, Engineering and Technology Research (IJSETR) Volume 6, Issue 12, December 2017
2. A. D. Kulkarni, *Computer vision and fuzzy-neural systems*. Prentice Hall PTR, 2001, ch. 2 and ch.6.
3. R. Jain, R. Kasturi, B. G. Schunck, *Machine Vision*, McGraw-Hill 1995, ch. 14.
4. D. A. Forsyth, J. Ponce, *Computer vision: a modern approach*. Prentice Hall Professional Technical Reference, 2002, ch. 15
5. A. Saxena, J. Driemeyer, A. Y. Ng, *Robotic grasping of novel objects using vision*, The International Journal of Robotics Research, vol. 27, no. 2, pp. 157–173, 2008.
6. S. Manzoor, R. U. Islam, A. Khalid, A. Samad, J. Iqbal, *An open- source multi-DOF articulated robotic educational platform for autonomous object manipulation*, Robotics and Computer Integrated Manufacturing, vol. 30, no. 3, pp. 351–362, 2014.
7. T. P. Cabre, M. T. Cairol, D. F. Calafell, M. T. Ribes, J. P. Roca, *Project-based learning example: controlling an educational robotic arm with computer vision*, Tecnologías del Aprendizaje, IEEE Revista Iberoamericana de, vol. 8, no. 3, pp. 135–142, 2013.
8. Pallav Doshi, Shubhankar Punktambekar, Niraj Kini, Simarjeet Singh Dhani, *Object Detection and its Application using Convolutional Neural Network*
9. Robotic Arms Guide, Available: <https://uk.rs-online.com/web/generalDisplay.html?id=ideas-and-advice/robotic-arms-guide>
10. A.N.W.QI, K.L.VOON, M.A.ISMAIL, N.MUSTAFFA, M.H.ISMAIL, *Design and Development of a Mechanism of Robotic Arm for Lifting, Part 1*, 2nd Integrated Design Project Conference (IDPC) 2015, Faculty of Mechanical Engineering, Universiti Malaysia Pahang, 11 Dec 2015